

DIMENSIONS

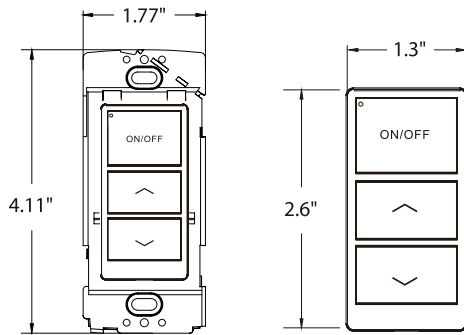

WALL MOUNT PLATE



PORTABLE CONTROLLER



ADDITIONAL FEATURES

- Bluetooth 5.0 connects to light groups via the IntelliCast app.
- Separate DIM+/DIM-, ON/OFF buttons.
- Left corner LED indicator for low battery.
- Mountable on flat surfaces or switch boxes, or usable as a remote.
- Compatible with standard single outlet box.

FEATURES

This IntelliCast Bluetooth wireless wall switch is a versatile, battery powered solution designed for seamless control of IntelliCast devices. It supports multiple functions, including ON/OFF and enables raised/lowered brightness adjustment. The switch also functions as a remote controller, allowing operation of your IntelliCast system from anywhere within its Bluetooth range, to ensure reliable, secure communication.

INPUT POWER	3V - CR2032 Battery
BATTERY LIFETIME	5-8 Years*
WIRELESS FREQUENCY	2.4GHz ± 75MHz
WIRELESS RANGE	100ft Max
WIRELESS PROTOCOL	Bluetooth 5.0
OPERATING TEMP.	0°C to 30°C, 32°F to 86°F
STORAGE TEMP.	-18°C to 50°C, -0.4°F to 122°F
HUMIDITY	5-90%
IP RATING	IP20
COLOR	White (WH)
WARRANTY	5-year Warrant
COMPLIANCE	UL1376, RoHs
SAFETY	FCC ID: 2A26YLTKTVT2022 DID: D061367 DLC: NLTRC5KL0TN

* BATTERY LIFE IS BASED ON APPROXIMATELY 20 PRESSES PER DAY. FREQUENT OR PROLONGED "PRESS AND HOLD" MAY REDUCE BATTERY LIFE.



CONSTRUCTION

Housing material consists of fire-rated UL 94-V0 flame resistant plastic; an IP20 rating protects against dust and small particle pollutants. Available in a modern and versatile white finish.

Can be mounted onto flat surfaces or on a switch box via wall plates.

Screwless, snap-on wall mounting plate included.

Face plates (ie. Decora switch plates) not included or available through Elite. Compatible with any standard screw-in Decora face plate. Opening dimensions: 2-5/8" x 1-5/16".

INSTALLTION

Suitable for surface mounting using a wall mounting plate or switch box. Compatible with face plates but includes only stanard wall mounting plate, without face plate.

OPERATION AND ELECTRICAL INFORMATION

Utilizes Bluetooth v5.0, with a transmission range of 100 feet, at 2.4 GHz \pm 75MHz. Operates using a single CR2032 battery. DC 3V input voltage.

2.4GHz wireless mesh technology with AES 128-bit encryption lighting control can connect 100 devices per group with a max distance of 98 feet in line barriers or corners.

Compatible with Elite IntelliCast mobile application.

Bluetooth Mesh

System control of multiple luminaires per switch is achieved by a Bluetooth mesh network, eliminating the need for routers and gateways. Luminaires work with wireless or embedded switch, and can be shipped pre-installed with daylight harvesting controls, occupancy sensors, and/or power packs for individual or room lighting control.

Energy-efficient, Comfortable, Convenient

Paired luminaires can be activated and programmed at the push of a button; programming can be used to make luminaires automatically compensate for levels of in-door brightness, saving energy and reducing visual discomfort.

* In accordance with NEC, the wall switch cannot function as the primary and only means of control. The fixture must receive a constant 120V supply, with control provided via an approved dimming interface or remote control system.

WARRANTY

5-year warranty for parts and components (labor not included).

LISTING

UL1376 Compliant.
DLC listed.
RoHs compliant - Contains no mercury or lead.
Rated IP20 for ingress protection against dust.

SCAN TO DOWNLOAD THE APP



WALL MOUNT CONTROL



FACE PLATE
(Sold Separately)

PORTABLE REMOTE CONTROL



ORDERING

EXAMPLE: IC-BLE-SW3-3V-WH

SERIES	VOLTAGE	FINISH	OPTION
IC-BLE-SW3	3V	WH - White	IntelliCast® Technology Configuration Tool

THE APP

The IntelliCast app by Elite Lighting allows validated end users (electrical contractors, sales agents, or facility maintenance professionals) to startup, configure, and troubleshoot wirelessly from a compatible smart phone or tablet.

The mobile app is optimized for efficient on-site startup and maintenance. It allows end-users to easily modify the settings and operation of fixtures, sensors, and wall switches in a group to meet energy code requirements. For larger installations, multiple users may use the mobile app simultaneously to reduce on-site time.

BENEFITS

- Complete control for applications using this room-based system
- Bluetooth-enabled app for iOS and Android devices
- Auto configuration and plug-n-play connectivity for simplified installation
- Intuitive interface and user-friendly wall stations for precise control

MAKE COMMISSIONING OF YOUR LIGHTING EASY



Add Luminaires

- Add/ Delete
- Individual Dimming
- CCT Adjustable
- 100 Luminaires per Group, 30 Groups Max

Create Groups

- Select Individual Lights
- Add to Group
- Link Groups
- Delete Groups
- Group Settings
 - Auto Settings
 - Motion Sensor
 - Daylight Harvesting
 - Time Delay
 - Program Presets

Switches

- Pair App to Switch
- Three Types of Switches
- Switch will Provide Options

Scenes

- Create / Edit Scenes
- Modify Presets

QR Codes

- Gain Admin Access
- Gain User Access
- Share Codes

More Settings

- Create Schedules
- Find QR Codes
- Circadian Rhythm Settings
- Luminaire Information
- Converter & Sensor Info
- Nearby Lights
- Function Testing
- Auto Calibration
- Trim Settings
- Bluetooth Radio Settings
- App Version Info