

**Triac-Phase Cut/Triac ELV/0-10V/1-10V PWM/Potentiometer (5 in 1) Dimmable
0-10V/1-10V/Potentiometer/10V PWM (4 in 1) CCT Dimming**

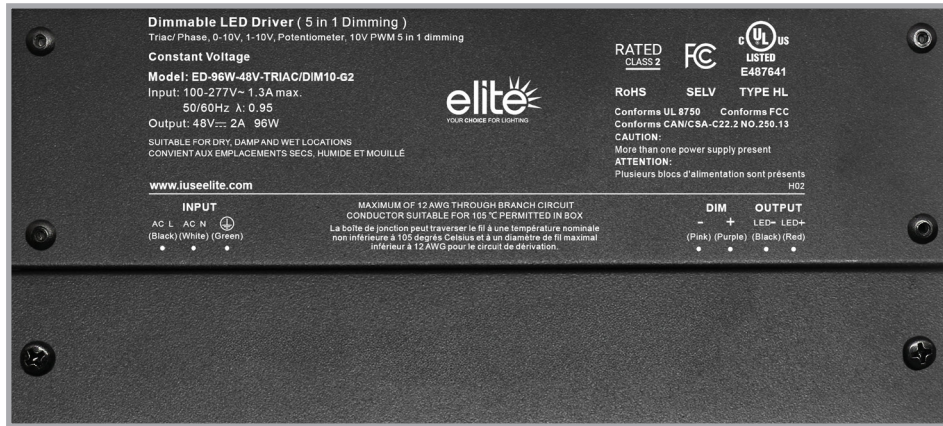

Output: Constant Voltage

Range: Primary voltage - universal (100-277V)

Efficiency: Up to 89%

Protections: Short circuit/ Over load/ Over Temperature

Dimming Function: Phase Dimming: works with forward phase, MLV and reverse phase, ELV TRIAC dimmers

0-10V Dimming: 0-10V/1-10V/Potentiometer/10V PWM 4 in 1

Dimming Range: Dimming range down to 0.1% on 0-10V, 1-10V and 10V PWM in 120-277Vac

Frequency Range: 50 - 60Hz

Working TEMP: -40°C to +60°C / -40°F to 140°F

Mounting: Vertical or horizontal surface mount

Warranty: 5 years Warranty

ED-96W-48V-TRIAC/DIM10-G2

Model	Input Voltage	Output Voltage	Wattage	Rated Current	Location	Certificate
ED-96W-48V-TRIAC/DIM10-G2	100-277VAC	48V	96W	2A	Dry, Damp & Wet Locations	FCC, cULus, Class 2, RoHS

DIMENSIONS

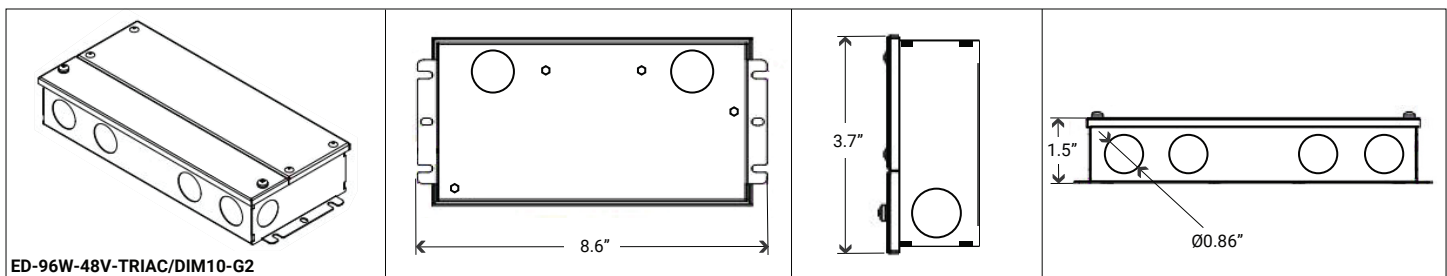

Technical Details

Model	ED-96W-48V-TRIAC/DIM10-G2	
Certificate	Class 2 / FCC / cUL / RoHS	
Output	DC Voltage	48V
	Voltage Tolerance	±0.5V
	Voltage Regulation	±0.5%
	Rated current	2A
	Rated power	96W
	Load Regulation	±1%
Input	Voltage Range	100-277VAC
	Frequency Range	50 - 60Hz
	Power Factor @ full load	0.99@120VAC 0.97@277VAC
	THD(Typ.) @ full load	<20%@120VAC & 277VAC
	Efficiency @ full load	≥86%@120VAC ≥89%@277VAC
	AC Current (Max.)	1.3A
	Inrush Current (Typ.)	20A, 1.6ms@50%120VAC 25A, 1.2ms@50%277VAC
	Leakage current	<0.5mA
Protection	Short Circuit	Shut down o/p voltage, re-power on to recover after fault condition removed
	Over Load	≤120% constant current limiting, auto-recovery after fault condition removed
	Over temperature	Shell surface temp. 100°C±10°C shut down o/p voltage, automatically recover after cooling
Environment	Working TEMP.	-40°C to +60°C / -40°F to 140°F
	Working Humidity	20 - 95%RH non-condensing
	Storage TEM., Humidity	-40 - +80°C, 10 - 95% RH non-condensing
	TEMP. coefficient	±0.03%/°C (0 - 50°C)
	Vibration	10~500Hz, 5G 12min./1 cycle, period for 72min. each along X,Y,Z axes
Safety & EMC	Safety standards	UL8750 CAN/CSA-C22.2 No.250.13
	Withstand voltage	I/P-O/P: 1.8KVAC I/P-FG: 1.8KVAC O/P-FG: 1.8KVAC
	Isolation resistance	I/P-O/P: 100MΩ/ 500VDC/ 25°C/ 70% RH
	EMC Emission	FCC 47 CFR Part 15 ,Subpart B

Notes

1-All parameters not specifically mentioned are measured at 120VAC input, rated load, and 25° (77°F) ambient temperature.

2-Tolerance: includes setup tolerance and load regulation.

Efficiency Curve (efficiency vs output load)

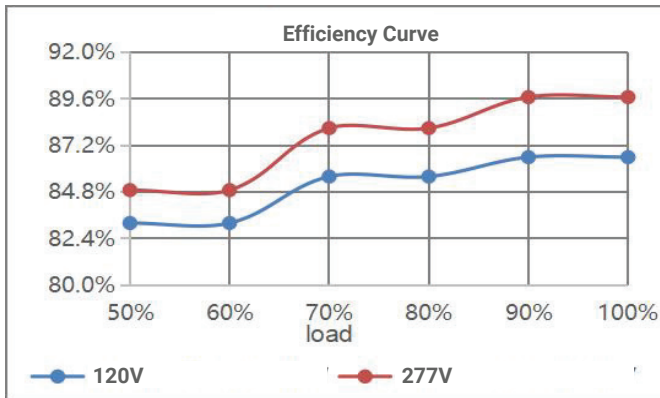

Derating Curve (output load vs TEMP.)

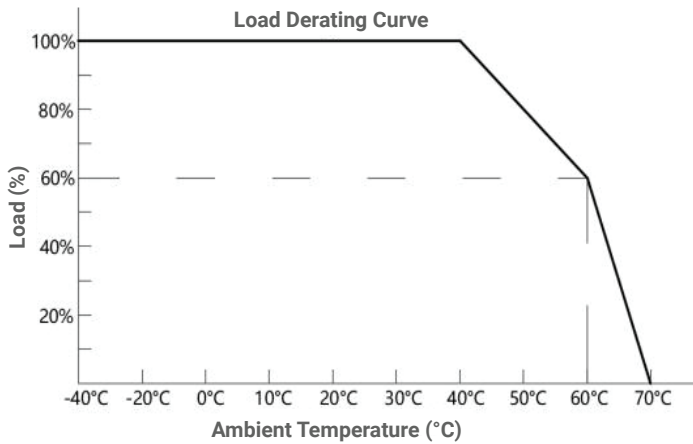

Power factor curve

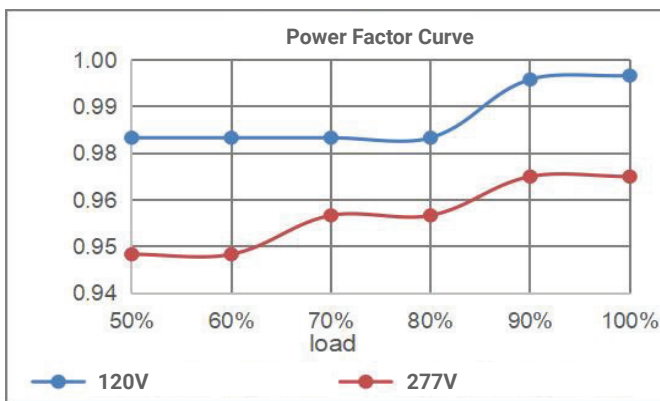

Dimming Operation and Wiring Diagram

TRIAC & 0/1 - 10V

When using two dimming methods at the same time, make sure the LED light is set to maximum output first. The brightness can then be adjusted with the second dimming method.

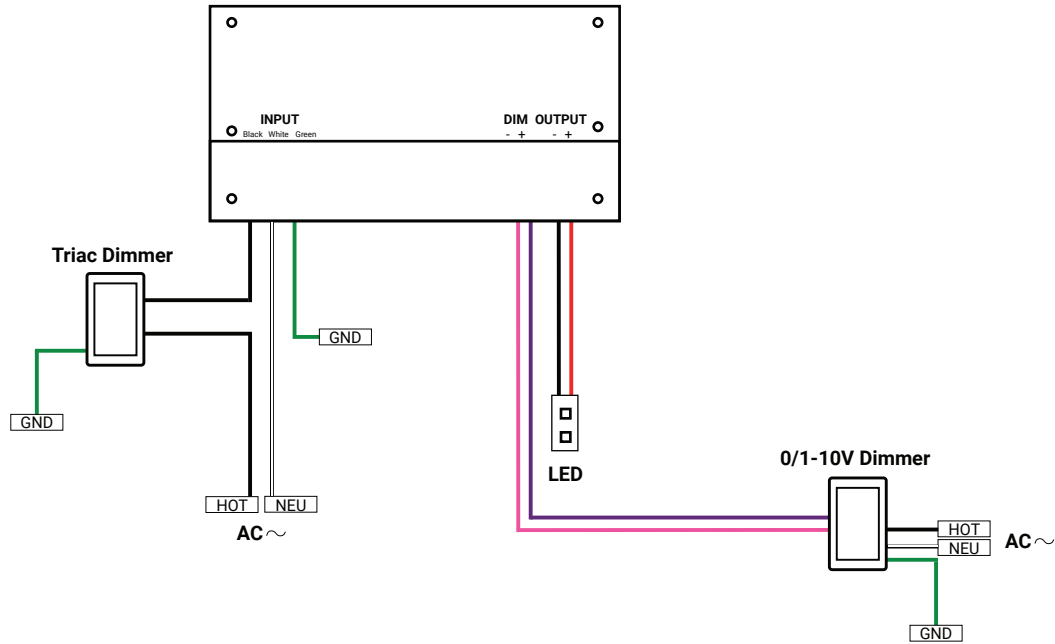

Single Dimming Method: TRIAC/Phase-Cut Dimming

1-The Pulse-Width Modulation (PWM) of the output voltage can be adjusted through the input terminal of the AC phase line (L) by connecting a phase/TRIAC dimmer or lighting control system.

2-Works with forward-phase (MLV) and reverse-phase (ELV) TRIAC dimmers or lighting systems.

3-Minimum loading is approximately 10%.

4-Use dimmers with a power rating at least 1.5 times the output power of the driver.

TRIAC

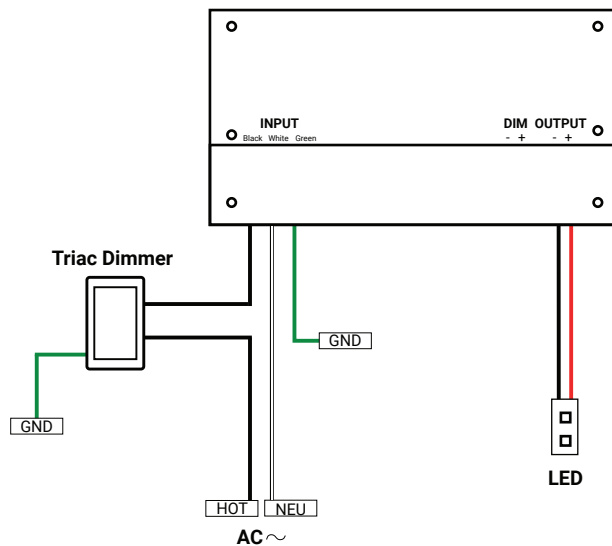

Using one Dimming Method: 0-10V / 1-10V / 10V PWM / Potentiometer Dimming

0-10V / 10V PWM

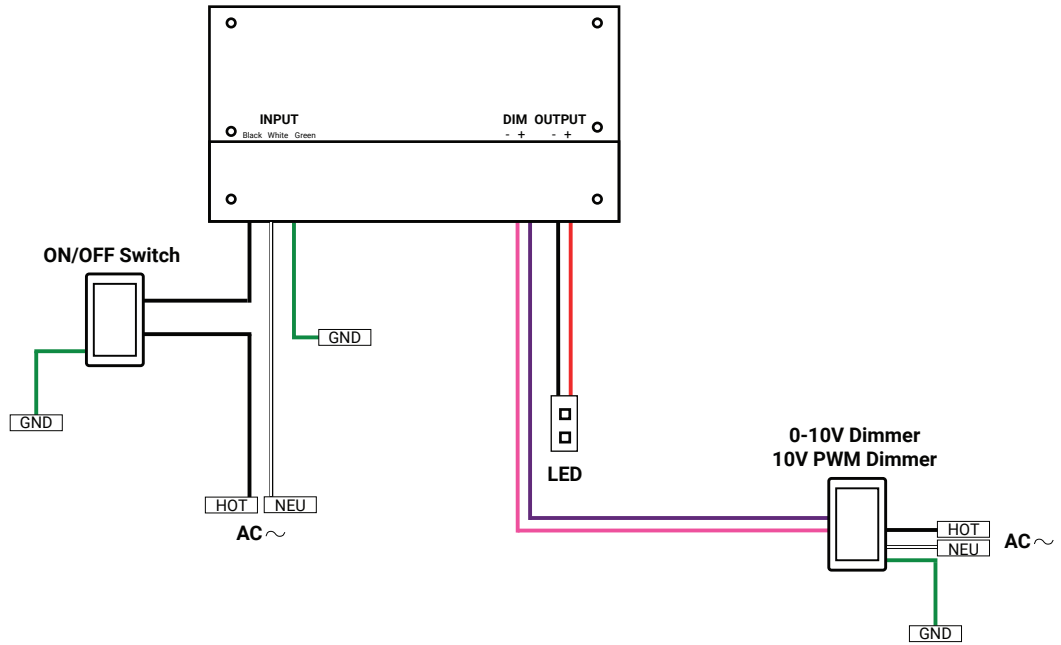

0/1 - 10V

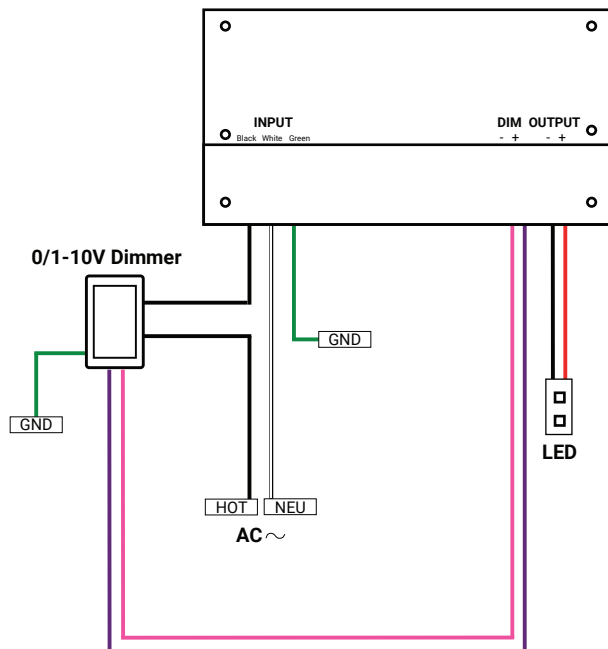

1-10V / Potentiometer

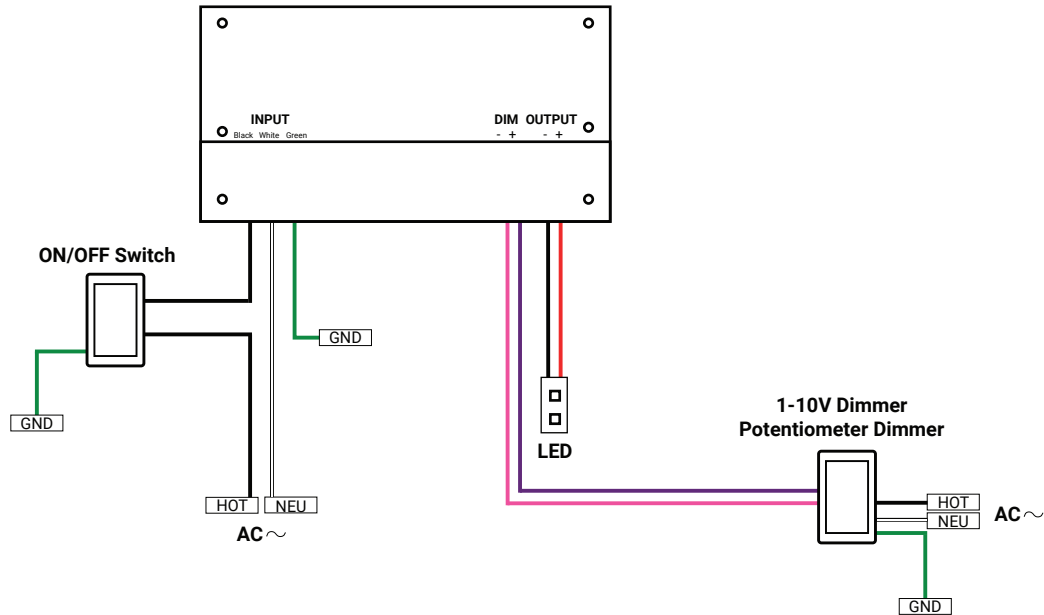

Dimmer Compatibility Chart

TYPE	BRAND	MODEL	TYPE	BRAND	MODEL
DIM10	Leviton	IP710-DLZ	Phase-Adaptive Dimmers	Lutron	PD-6WCL
	Leviton	IP710-LFZ		Lutron	MA-PRO
	Lutron	MS-Z101		Lutron	DVRF-6L-WH
	Lutron	DVSTV		Lutron	MACL-153M-WH
	Eaton	SF10P-W		Lutron	DVCL-153P
	Legrand	CD4FBL3PW		Lutron	CTCL-153P-WH
	Legrand	CD4FBLW		Lutron	PD-5NE
				Lutron	MRF2S-6ELV120
				Lutron	DVRP-253P
				Lutron	CTRP-253P-WH

WARNING

- This driver must be installed by a qualified professional.
- Provide adequate ventilation around the driver to ensure proper heat dissipation.
- Confirm all wiring connections are correct before testing to prevent damage to the light or power supply.
- If the driver is not operating correctly, do not attempt to repair it yourself.