

# B26RIC-LED 6" REMODEL IC LED SHALLOW HOUSING

**SAME DAY**  
SHIPPING AVAILABLE



**IC**  
RATED **900**  
LUMENS

INPUT VOLT.	INPUT FREQ.	INPUT CUR.	INPUT POWER	THD	POWER FACTOR	LUMENS
120/277	50/60Hz	150mA/65mA	18W(+/-5%)	<20%	>0.9	900
120/277	50/60Hz	116mA/50mA	14W(+/-5%)	<20%	>0.9	650

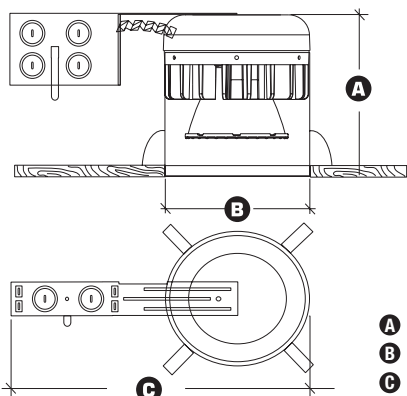

- A** Height = 5"
- B** Cut-out = 6-1/2"
- C** Length = 13"

**DESCRIPTION** - 6" LED dedicated Shallow Remodel IC housing with integral LED heat management casting and driver (installed on junction box). Designed for remodel installations and suitable for use in insulation covered or non-insulation covered ceilings. Lighting is smooth and comfortable while using 75% less energy than the equivalent 100W PAR38 and 25% less than the common 32W CFL. Plus, the eco-friendly Elite LED system features 70% lumen maintenance at 50,000 hours life, with Energy Star and California Title-24 (compliances pending).

**FEATURES** - Greater light output than an 32W CFL or a 100W PAR38. Elite LED luminaires are ideally suited for use in hospitality, health care, commercial, retail and residential applications.



**OPTICS** - Elite's optics gather the light scattered by the LED chip, shape it into a functional beam with state of the art reflectors, integrate the light through a smooth lens to minimize brightness, then top it all of with a glare reducing cone that has a 55-degree cut-off. Now you have the Elite engineered, superior quality, light engine; producing over 900 lumens.

**DURABILITY** - Die-cast aluminum housing and heat management system are engineered for extremely long life and service period. Heat sink is attached to top of housing. The LED light engine is attached to the die-cast heat sink and is easily replaceable and upgradable. Life tests have shown the Elite light engine output will be maintained at 70% of initial at 50,000 hours of operation. Our superior design allows for installation in construction that requires Elite Air-Shut™ system. Our LED driver is rated for 50 to 60 Hz, produces less than 20% THD, has a power factor between 0.90 and 1.00 and is thermally protected for additional safety. Elite's driver is installed on the junction box cover so it may be serviced from below the ceiling.

**REPEATABLE** - Repeatability means quality. From our chip selection process, to our driver, to the thermal management, the Elite LED Module is engineered for quality. All Elite LED luminaires are rated at 90+ CRI and 27K, 30K, 35K, 40K and 50K, as rated and tested to LM-79 and LM-80 standards by a certified laboratory. California Title 24-2013 and Energy Star compliance are standard.

**DIMMABLE** - The Elite LED system is fully dimmable down to 10% of initial light output with a 0-10 Volt dimmer when ordered with the following options (DIM10-MVOLT). Fixtures can be shipped with a Lutron Hi-lume A series Driver which can be dimmed with Lutron Dimming Systems when ordered with the following options (120-LUTH, 277-LUTH). Triac & Electronic Low Voltage dimming driver also available when ordered with the following options (DIMTR-120). Consult Factory for details.

**HOUSING** - Die-formed aluminum for maximum heat dissipation and rust protection. Housing can be installed in 1/2" to 1-3/8" thick ceilings. Housing is IC rated for direct contact with insulation and can be used in IC and NON-IC applications. May be installed in 2" x 6" joist construction.

**INSTALLATION** - For fast and easy installation in existing plaster or mechanical ceilings the housing installs from below the ceiling. Four preinstalled spring clips with secure the housing firmly into ceiling to accommodate different ceiling thicknesses form 1/2" to 1-3/8".

**JUNCTION BOX** - UL Listed for through-branch circuit wiring, provided with eight 1/2" knockouts and four Romex knockouts with true pry-out slots and strain clamps. Driver is installed on the junction box cover so it may be serviced from below the ceiling.

**THERMAL PROTECTION** - Standard thermal protection device guards against improper installation and misuse of insulation material.

**OUR WORD** - The Elite LED lighting system carries a five-year carefree warranty for parts and components. (Labor not included.)

**LISTING**

c-UL-us - listed for Damp location  
 c-UL-us - listed for feed Through Wiring  
 c-UL-us - listed for Direct Contact With Insulation  
 LM79 / LM80  
 Covered by U.S. Patent Numbers: D6423175S, D615239S

**DIMMING INFORMATION**

DIMTR (Triac & Electronic Low Voltage Dimming)  
 DIM10 (0-10V Dimming)  
 LUTH (Lutron® Hi-lume® Dimming)





**ITEM SELECTOR:** Example: **B26RIC-LED-900L-DIM10-MVOLT-MD-30K-AT-L661-W-WH**

TYPE	650L SERIES	900L SERIES	OPTICS	CCT	CRI	AIR-SHUT	EMERGENCY	TRIM	BAFFLE	REFLECTOR	TRIM/RING
B26RIC-LED	<input type="checkbox"/> 650L-DIMTR-120 <input type="checkbox"/> 650L-LUTH-120 <input type="checkbox"/> 650L-LUTH-277 <input type="checkbox"/> 650L-DIM10-MVOLT	<input type="checkbox"/> 900L-DIMTR-120 <input type="checkbox"/> 900L-LUTH-120 <input type="checkbox"/> 900L-LUTH-277 <input type="checkbox"/> 900L-DIM10-MVOLT	<input type="checkbox"/> MD (Medium)	<input type="checkbox"/> 27K <input type="checkbox"/> 30K <input type="checkbox"/> 35K <input type="checkbox"/> 40K <input type="checkbox"/> 50K (85+ CRI Only)	<input type="checkbox"/> 85+ <input type="checkbox"/> 90+	<input type="checkbox"/> AT	<input type="checkbox"/> EMG	<input type="checkbox"/> L661 <input type="checkbox"/> L617	<input type="checkbox"/> W <input type="checkbox"/> P <input type="checkbox"/> SN <input type="checkbox"/> CP <input type="checkbox"/> BZ	<input type="checkbox"/> BZ <input type="checkbox"/> CL <input type="checkbox"/> CP <input type="checkbox"/> RG <input type="checkbox"/> MB <input type="checkbox"/> W <input type="checkbox"/> SN <input type="checkbox"/> SHZ	<input type="checkbox"/> BK <input type="checkbox"/> WH <input type="checkbox"/> CH <input type="checkbox"/> PB <input type="checkbox"/> SN <input type="checkbox"/> CP <input type="checkbox"/> BZ







## L661W-WH - PHENOLIC STEPPED BAFFLE (ORDERING INFORMATION) L661X- XX



**BAFFLE FINISH:**

				
BZ	CP	SN	W	P







**RING FINISH:**

						
BK	WH	CH	PB	SN	CP	BZ







## L617CL-WH - REFLECTOR (ORDERING INFORMATION) L617X- XX



**REFLECTOR FINISH:**

						
CL	CP	MB	RG	SN	W	SHZ

**RING FINISH:**

						
BK	WH	CH	PB	SN	CP	BZ

LED

6"

6 INCH LED SHALLOW TRIMS