

NOMINAL LUMENS	WATTAGE
6000	60 W

Based on 4000K, 90+ CRI. Actual wattage may vary +/- 5%

DYNAMIC PLATFORM

RGB + White Technology has a white color tuning range from 8000K to 1650K. RGB color range derived from the primary colors red, green and blue is used to create infinite color options in the RGB palette, adding colors together in varying amounts to create new ones. RGB Tunable White Technology enables users to adjust the color temperature, adding gradients of saturated colors. No longer restricted to white light LEDs, lighting designers and architects can manipulate a space with desired hues and shades, altering the color temperature of the room, creating the perfect environment. The use of RGB Tunable White Technology in healthcare and assisted living stimulates circadian rhythm, accelerating the healing process. Available in Lumenetix platform maintaining a constant CRI of 90+.

LUMENS	6000
CCT & DYNAMIC PLATFORMS	Lumenetix: RGBW-LTX-80K-16K (RGB + 80K to 16K) Elite platform: RGBW 60K-18K (RGB + 60K to 18K)
CRI	90+
COLOR QUALITY	2 Step MacAdam Ellipse
SIZE	2'x2', 2'x4', 1'x4'
MOUNTING	Recessed
DIMMING & CONTROL	DMX-512/RDM
EMERGENCY	PELI-S-20, PELI-S-100, PELI-S-250, PELI-S-400
LIFETIME	L70 at 50,000 Hours
PHOTOMETRIC TESTS	In Accordance with IES LM79-08, LM80 and TM-30, TM-21





FEATURES

The OD-LED blends the traditional look of an architectural volumetric troffer with a center acrylic diffuser, together with unmatched optical performance, delivering the latest in LED technology and lens innovation. The integrated LEDs are strategically angled behind the center indirect acrylic diffuser to maximize lumen output and provide even illumination across the full face of the luminaire. The consistency of the volumetric effect results in optimized visual comfort, enhancing the quality of illumination. The combination of energy savings and optical performance create the ideal choice for educational, medical, office and retail spaces.

OPTICAL SYSTEM

The LED light engine is secured to the body of the luminaire, with the body acting as a heat sink. A proprietary design of the lens results in zero pixilation, regardless of the viewing angle, with LEDs placed to promote a uniform appearance. The result is even illumination across the space, from luminaire to luminaire.

MAINTENANCE

The center acrylic diffuser can be removed, allowing easy access to LED boards and driver compartment, locking into place for secure closure of the luminaire. LED engines and drivers are removable and upgradable even after luminaire installation. Luminaire can be regularly and safely wiped down to ensure optimal performance.

OPTICAL SYSTEM

The LED light engine is secured to the body of the luminaire, with the body acting as a heat sink. A proprietary design of the lens results in zero pixilation, regardless of the viewing angle, with LEDs placed to promote a uniform appearance. The result is even illumination across the space, from luminaire to luminaire.

CONSTRUCTION

Body is constructed of heavy-duty 20-gauge cold rolled steel, post-painted and engineered for maximum strength and extended life. All corners interlock to prevent aesthetic damage to the luminaire, with sides and corners uniformly turned in and hemmed to remove sharp edges for safe handling and easy installation. Luminaire is supplied with multiple wiring entrances for easy daisy chain of luminaires, to add power packs, whips, or other accessories in the field, or for continuous row mounting.

FINISH

Post-painted with a 93% reflective white coat to improve luminaire efficacy, and all body components are seamlessly interlocked for added structural strength.

MOUNTING

Luminaires accommodate lay-in ceilings, Slot T, and T-bar suspension systems for 5/8" and 3/8" ceiling thicknesses. Four corner tie points are standard for safety wire support when required, with built-in earthquake clips, standard. Luminaires may be available with flange kits, surface mounted kits, and other options.

OPTIONS

Luminaires can be shipped pre-installed with whips, modular wiring systems, daylight harvesting controls, occupancy sensors, and/or power packs for individual or room control solutions.

DRIVER ELECTRICAL INFORMATION

Powered by high-quality constant-current power LED drivers which are rated for 50 to 60Hz at 120-277V input, produce less than 20% THD, and have a power factor of .90 to 1.00.

WARRANTY

Five-year warranty for parts and components. (Labor not included)

LISTINGS

c-UL-us - Listed for Feed Through Wiring.

Example: **24-OD-LED-RGBW-60K-16K-6000L-DMX-512/RDM-120**

FIXTURE SIZE	SERIES	PLATFORM	LUMENS	DIMMING	VOLTAGE	EMERGENCY	OTHER OPTIONS
24 - 2' X4'	OD-LED - LED Volumetric Troffer	ELITE PLATFORM RGBW-60K-18K	ELITE PLATFORM 6000L - 6000 lumens	ELITE PLATFORM ELDODMX.1 - EldoLED DMX	120V 277V	PELI-S-20 PELI-S-100 PELI-S-250 PELI-S-400	24FK - 2'x4' Flange Kit FBF - Internal Fast Blow Fuse SBF - Internal Slow Blow Fuse RIS - Radio Interference Suppressor USA - Made in America Compliance
		LUMENETRIX PLATFORM RGBW-LTX-80K-16K	LUMENETRIX PLATFORM 6000L - 6000 lumens	LUMENETRIX PLATFORM DMX-512/RDM - Standard Controller			



1.1 DMX512-A Protocol Specifications

DMX512-A is an acronym for Digital Multiplex, a communication protocol used to remotely control lighting dimmers and intelligent fixtures. It is designed to provide a common communications standard between these lighting devices regardless of the manufacturer. The 512-A after the DMX refers to the number of control channels used on one network segment (often called a 'universe') of devices. In a simple dimming system, one channel controls the intensity of the fixture. A single intelligent fixture such as the araya⁵ requires several channels to control its various parameters (one channel each for DIM, CCT, SAT, HUE).

DMX512A Specifications:

- DMX 512-A (Controller).
- A universe is 512 Channels.
- DMX value is between 0 and 255, where 0 is off and 255 is full on.
- The maximum number of devices in a daisy-chain wire run is 32, which include the controller and opto-splitter.
- The maximum network wire run is a distance of up to 1600 feet for non-RDM systems and up to 1000 feet for RDM systems.
- One device functions as the master (DMX controller) on a network, while the rest function as slaves (mergers, splitters, intelligent fixtures, etc.).
- Only the controller (master) transmits over the network, and all fixtures receive the same data.
- The final device in the daisy-chain must be terminated with a 120 ohm resistor between DMX+ and DMX- pins.
- It is recommended that the terminator for the final device be located in the control panel, if it falls within the recommended wiring distance.
- All wiring must be in a continuous run and daisy-chained.
- Star wiring is only allowed in conjunction with an opto-splitter.
- Do not run DMX control cable in close proximity to AC power lines. EM spikes from switching of high-current devices such as HVAC equipment or generators will induce noise into the DMX cable.
- The shield must be carried through between modules and properly grounded at one point only.
- Connections to DMX512-A-RDM accessory board: wire size to be 24AWG, and solid or stranded cables may be used. Stranded wire used must be tinned or installed with ferule connector.

RDM

DMX512-A control protocol that enables Remote Device Management for two-way communications for configuration, monitoring and system setup. Allows two way communication between lighting controller and the fixtures. Allows for remote setting of DMX start addressing. RDM signals are sent back the other way, but not constantly. Controller can ask one or more devices for query feedback. RDM packets are inserted in-between the existing DMX data packets being used to control the lighting. The DMX Control Console will broadcast up to 512 channels over one DMX cable (max. run of 1000 feet for RDM). Some of these channels may not be used, but will still be transmitted, as required by the protocol. It must be set to a desired channel (001, 002, 003, 004, etc.) to control the connected light fixture. This is usually accomplished using RDM. This desired 'channel' is commonly known as the DMX address. When addressing fixtures, it is not recommended to skip addresses.

When RDM is not available with the control system, it is permissible to use the Lumenetix commissioning tool (the araya⁵ Tunable Color 2.0 iOS App) to set the address of the slots. The instructions to configure the DMX channels can be found in the separate araya⁵ Tunable Color Instruction Manual.

The DMX512-A interface follows the ANSI E1.11-2008 (R21013) standard. Four address slots are allocated to each interface board and control the Dim level, CCT, Saturation and Hue of the araya⁵ modules connected to the board.

- **Lumenetix DMX512 Protocol and Wiring Description**

Default Lumenetix DMX512-A Slot Allocation:

Slot	Function
1	Dim Level
2	CCT
3	Saturation Level
4	Hue



1.2 DMX512-A Electrical Specifications

Parameter	Range	Remarks
ESD Protection	±15KV (air), ±8KV (conducted)	Per IEC 61000-4-2
Termination	Recommended	The DMX512 bus termination rules apply
Directionality	Receive only	
Frequency stability	±20ppm	
Load per port	1/256	1/8 of Nominal RS-485
Isolation	3KV _{rms}	

DMX512-A Control Systems (recommended list)

Choreo
Cognito
Crestron Greenlight System
Entec
ETC Mosaic
ETC Paradigm
Fresco
Interactive Technologies
Lutron HomeWorks QS
Lutron Quantum
Nicolaudie
Pathway Connectivity
Pharos
Traxon Ecue
Vantage Controls

*Recommendations are subject to change. Consult your Lumenetix representative for the most updated list.

DMX512-A Recommended Internal / Field Wiring

TMB Cable ProPlex DMX

PC224T: 2-pair DMX512 cable, overall foil and braid shielding with drain wire. UV and fungus resistant. Fully rated for installations, yet easy handling for light duty portable applications. **PC224TW:** Same as above, with white jacket.

For use as DMX in/out under one jacket:

PC244T: Two individually shielded pairs and drain wires. UV resistant. Color coded foil shielding for easy reference.



DMX512-A PROTOCOL

1.3 DMX512-A Recommended Field Wiring

Liberty 24-2P-485 (Non-Plenum), 24 AWG, 2 pair dual 120 ohm, 11.2 pf/ft low capacitance (Wago, XLR and PHX connectors)

Liberty 24-2P-P485 (Plenum), 24 AWG, 2 pair dual 120 ohm, 11.2 pf/ft low capacitance (XLR and PHX connectors)

Belden #9842 (Non-Plenum), 24 AWG, 2 pair dual shielded 120 ohm, 12.8 pf/ft low capacitance (XLR and PHX connectors)

Belden #89842 (Plenum), 24 AWG, 2 pair dual shielded 120 ohm, 12.8 pf/ft low capacitance (XLR and PHX connectors)

Please refer to wire manufacturer's lighting catalog for and/equals as required by code.

Category Wire or Equal

The Entertainment Services and Technology Association (ESTA) does not define a maximum run length for DMX over Cat5 since many factors will affect the maximum run length, such as number of devices, number of splices in the cable, the strength of the DMX transmitter(s), if Remote Device Management (RDM) is being used, and sources of interference. ESTA does state (again, in ANSI E1.21-2):

"A properly selected and installed DMX512 cable should provide acceptable signal strength for runs of 300m (1000ft). Please note that the technical requirements, such as run-length and topology for other networking technologies, such as Ethernet, should be considered if using the installed cable for another networking technology in the future is anticipated."

Cat5 or equivalent is not preferred as a portable cable since it is not as rugged as other DMX cables. Male RJ45 connectors are especially prone to breakage over repeated re-connections.

LUMENETIX RECOMMENDATION:

CAT 5E -150 FEET

CRESTRON

DM-CBL-8G-NP

DM-CBL-8G-P

CAT 7- 330 FEET

CRESTRON

DM-CBL-ULTRA-NP

DM-CBL-ULTRA-P

DMX512-A Recommended Field Connectors (or Equal)

WAGO 221

PHOENIX CONTACT

XLR NEUTRIK

CRESTRON

RJ45 DM -8G-CONN

RJ45 IDC DM-CONN

DMX512-A Wiring Connections

Signal	Description	Pin Colors (4-Pair Cable)	Pin Colors (2-Pair Cable)	3-pin XLR connector	5-Pin XLR connector	5-Pin PHX connector
Signal Common		White/Brown and Brown	White/Blue and Blue	1	1	1
Data (-)	Primary Data Link	Orange	Orange	2	2	2
Data (+)	Primary Data Link	White/Orange	White/Orange	3	3	3
Data2 (-), or not used	Optional Secondary Data Link				4	4
Data2 (+), or not used	Optional Secondary Data Link				5	5

XLR Connectors (5-Pin)

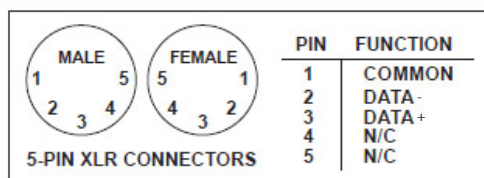

RJ-45 Connector Pin-Out (T568B)

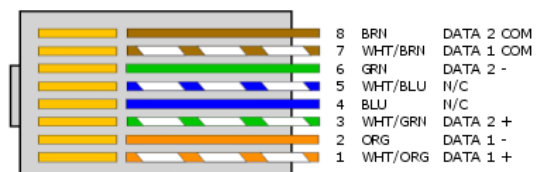



DMX512-A PROTOCOL

1.4 DMX512-A Controller Example DMX512A Example

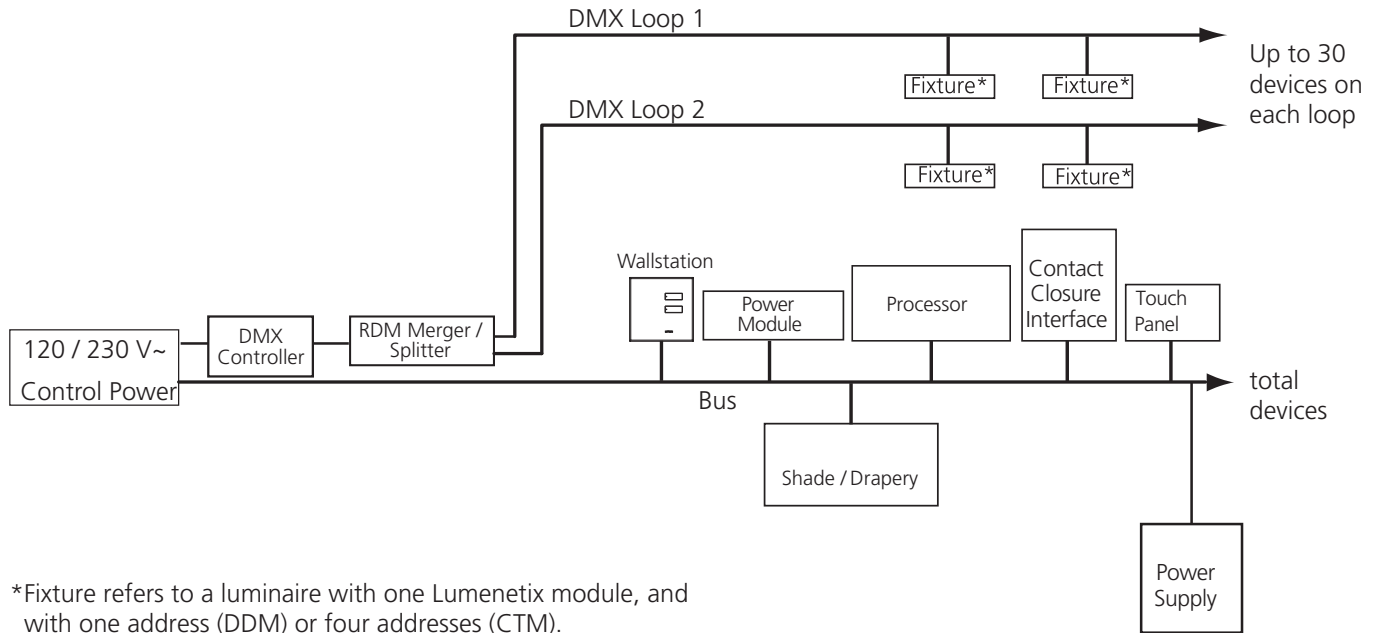

*Fixture refers to a luminaire with one Lumenetix module, and with one address (DDM) or four addresses (CTM).

DMX512-A Drain Wire Connections

Drain wire connections are required as follows.

Shielding

To add another level of protection from electromagnetic noise, a grounded shield is added over the twisted pair wires. When this is enclosed in a protective jacket, to avoid ground loops and electromagnetic contamination of the ground system, all control ground wiring, including cable shields and drain wires, should be treated like sensitive current-carrying conductors. All control ground wires should be insulated (not bare) and the same wiring practices should be observed with ground wires as with other sensitive signals. Care must also be taken when designing control wiring to ensure that each shield is connected to only a single ground point. You should establish this point at a central location, like a control panel or cabinet, and avoid all connection to grounds in the field. A control ground is sometimes referred to as an isolated ground (an oxymoron) for this reason, but the term single-point ground is more accurate.

Method-1

A typical two-pair shielded cable can be prepared for termination to the terminals with the drain wire cut off. This is usually done at the field end of the cable where no shield grounding is desired. You will then use insulating tape or heat-shrink tubing to protect the cable from contamination and to prevent accidental grounding of the shield or drain wire. An accidental ground at this point would almost certainly create an undesirable ground loop.

Method-2

A typical two-pair shielded cable can be prepared for termination to the terminals with the drain wire cut off. The drain wire, which is an uninsulated conductor, is sleeved with a insulating tubing to prevent accidental grounding. The crimp-on lug is valuable in this instance to retain the tubing. Insulating tape or heat-shrink tubing is again used to protect the cable from contamination and to prevent accidental grounding, since any accidental connection between the drain wire and a chassis, frame, or enclosure would almost certainly create a ground loop.



DMX512-A WIRING DIAGRAMS

2.1a DMX512-A-RDM Accessory Card Wiring Diagram araya⁵ Logic Module (ALM) with Linear Arrays

Notes:

1. 24V power (red/black) is Class-2 rated.
2. Adapter is configured at factory for DMX inputs.
3. If more than one line of DMX is needed, then a DMX Splitter must be used to create multiple independent branches of a DMX signal and/or to extend the usable distance of each branch. Each of the splitter's 4, 6, 8, or 16 output ports generates an independently protected DMX signal.

DMX SLOTS SET BY RDM OR
BY TUNABLE COLOR 2.0 iOS APP

(MAX. OF 8 MODULES CAN BE
COMMISSIONED AT A TIME)

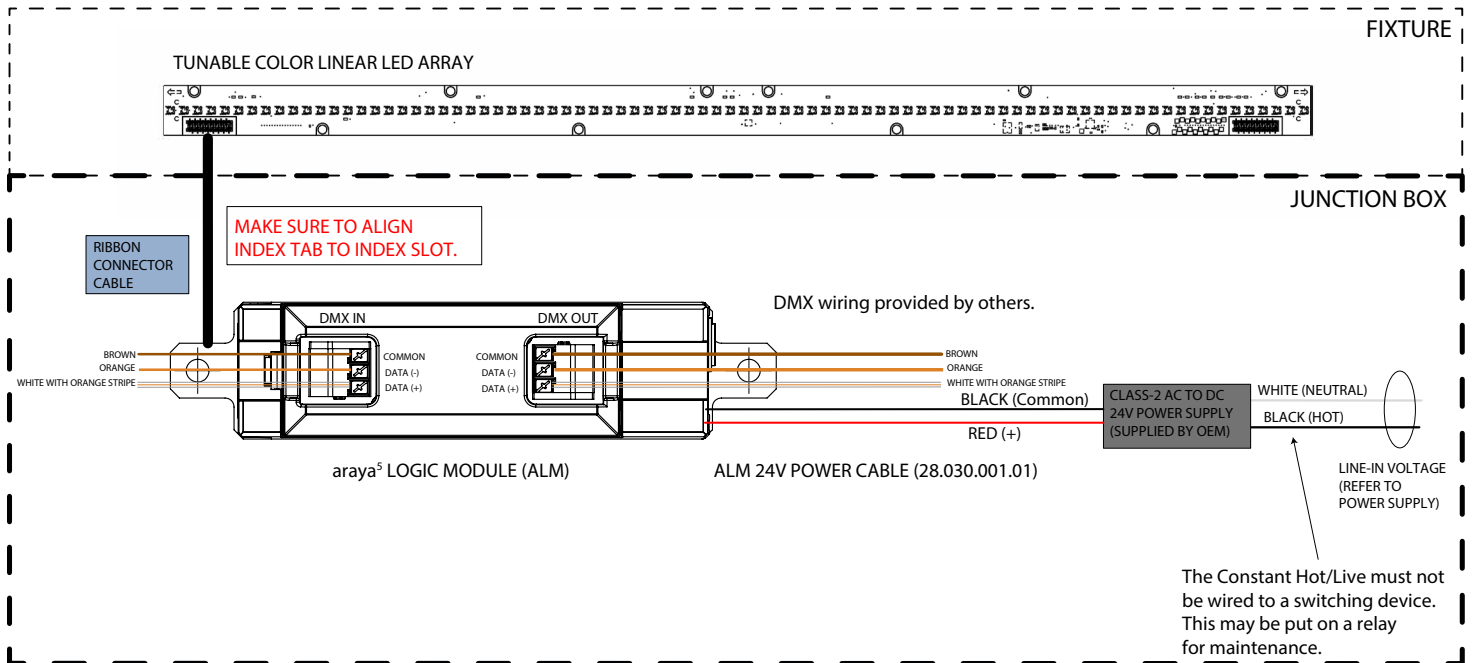

NOTE: BLUETOOTH OPERATION IS FOR COMMISSIONING THE MODULES ONLY, NOT FOR CONTROLLING THEM.



- **ELDO DMX Protocol and Wiring Description**

How to wire DMX/RDM lighting systems

DMX/RDM is a robust and reliable system for lighting control. However, if not implemented correctly, problems can arise such as random flashing of lights, erratic operation and delays in responding to commands. This document explains the best practices in DMX wiring.

Below, a typical DMX universe is shown. The DMX controller sends signals over the DMX cable to the drivers. At the last driver, the cable has to be terminated with a 120Ω resistor to prevent reflections of the signal.

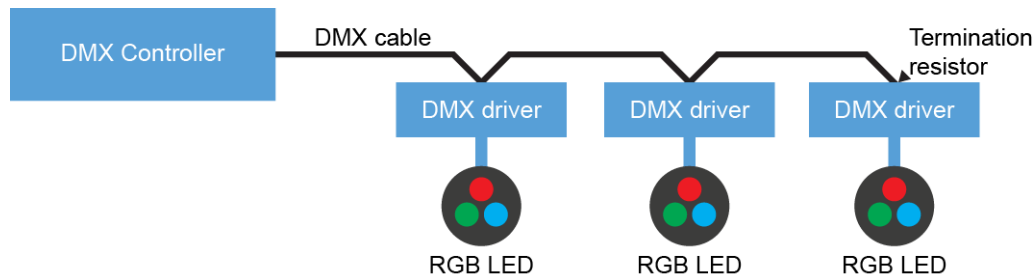

Figure 1 – Typical DMX universe

Important things to consider are:

- DMX is a three-wire system. Use all three!
- DMX is based on the EIA-485/RS-485 standard.
- Always use cable specifically designed for DMX / RS-485. These cables have an impedance of 120Ω and a low capacitance. For instance: Belden 9841 or 3105a.



Figure 2 – Belden 9841 cable

- DMX must be terminated with a 120Ω resistor to prevent reflections.
- A daisy chain topology should be used.
- After 32 unit loads a repeater/booster should be used.
- Keep cabling below 300 metres between the controller and the last driver.
- It is generally considered good practice to provide separate DMX in and DMX out/DMX thru connections to your fixture to aid in installation. This can be in the form of pigtails, RJ-45 connectors or 5-pin XLR-connectors.



Connecting the cable on eldoLED drivers with 'DMX in' terminals only

Drivers with only one set of DMX terminals (DMX in +, DMX in -, and DMX in shield) use a standard DMX bus topology (daisy chain). At the last driver, a 120Ω resistor must be connected between the DMX in + and DMX in - pins of the driver as termination. This method is compatible with RDM.

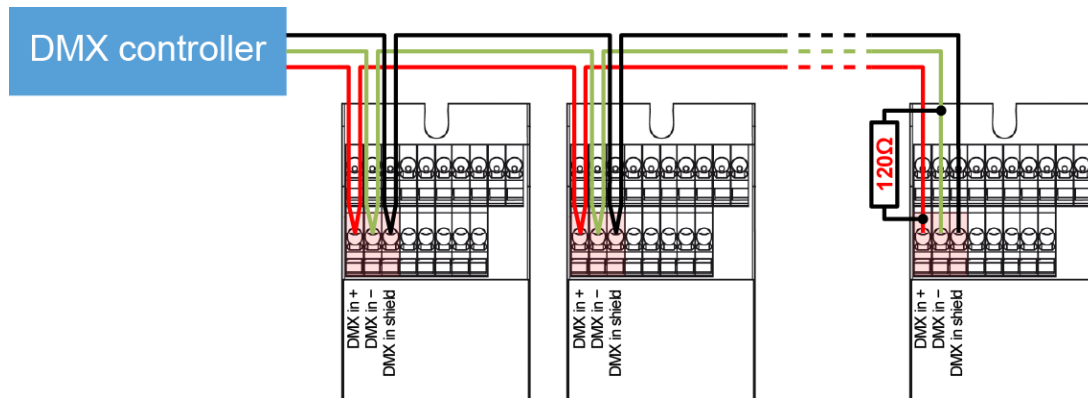

Figure 3 – Daisy chain topology with 'DMX in' only

Connecting the cable on eldoLED drivers with 'DMX in' and 'DMX thru' terminals

Some eldoLED drivers have an extra set of DMX terminals (DMX thru +, DMX thru - and DMX thru shield) in addition to the 'DMX in' terminals to make installation easier. Internally, these 'thru' terminals are electrically connected to the 'DMX in' terminals. These drivers also use standard DMX bus topology (daisy chain). The 'DMX thru' connections are compatible with RDM.

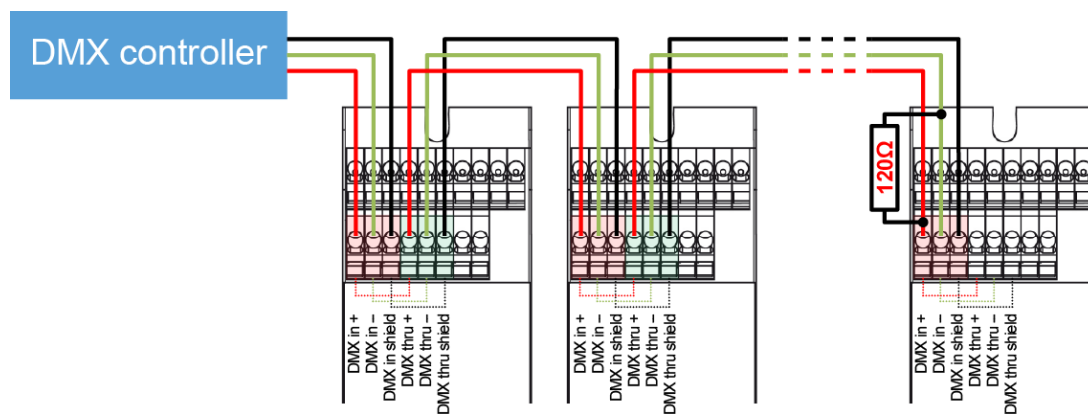

Figure 4 – Daisy chain topology with 'DMX in' and 'DMX thru'

Connecting the cable on eldoLED drivers with 'DMX in' and 'DMX out' terminals

Drivers with 'DMX out' terminals (DMX out +, DMX out - and DMX out shield) in addition to the 'DMX in' terminals provide a buffered DMX out signal. These drivers offer additional functionality on top of standard DMX. On some products 'DMX out' is called LEDsync.



- DMX out acts as a built-in booster or repeater, so no additional repeaters or boosters are necessary after 32 drivers.
- DMX out provides automatic driver addressing possibilities.
- With DMX out, it is possible to have mixed topologies instead of daisy chain only.
- Only the first driver on the 'DMX out'-chain (master) is visible on RDM – slaves behind are not visible. If RDM is required, use the 'DMX in' terminals instead of 'DMX out'.
- Each DMX out adds a delay of approximately 300µs. After 75 drivers, this delay will be visible.
- The maximum available DMX address is 480; DMX addresses 481 – 512 are reserved for 'DMX out'-features.
- If one driver in the chain fails, devices behind the failing driver will stop receiving DMX signals.
- Drivers without 'DMX out'-terminals or third party drivers should be first in the DMX chain, they cannot be connected behind drivers with 'DMX out'.

Termination with DMX out

With drivers that have DMX out terminals extra care should be taken with termination, depending of the configuration. In short: termination is necessary after each cable run, but not at any T/Y-connections. Some examples:

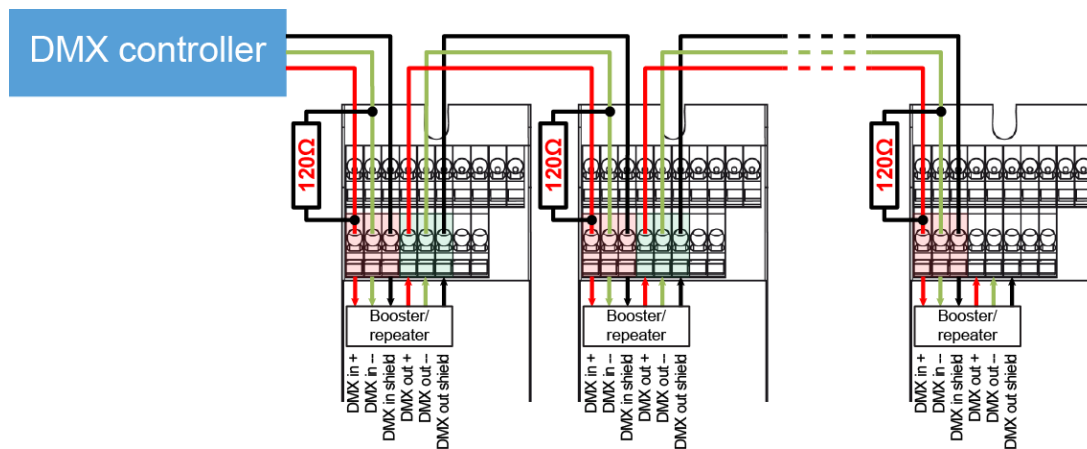

Figure 5 – Termination on each cable run

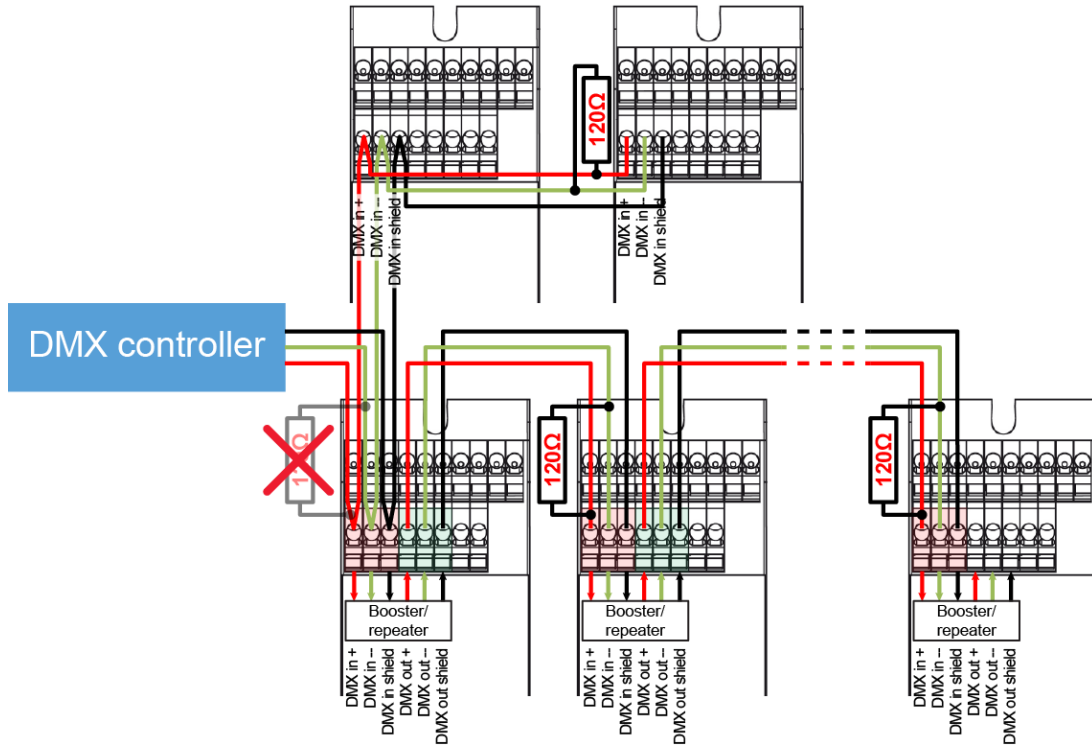

Figure 6 Mixed topology with daisy chain and DMX out

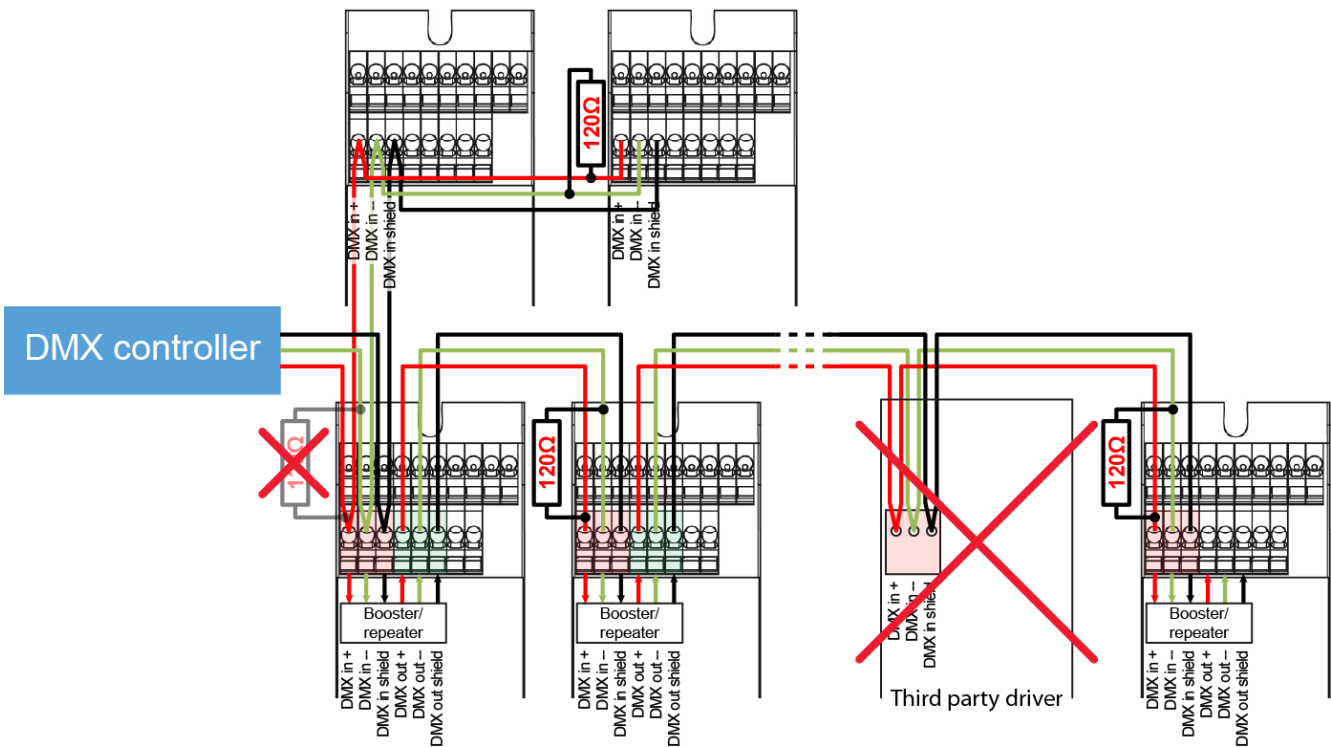

Figure 7 – It is not possible to have third party drivers in the DMX out-chain