

DLM ON/OFF/O-10 VOLT DIMMING FIXTURE CONTROLLER

LMFC-011

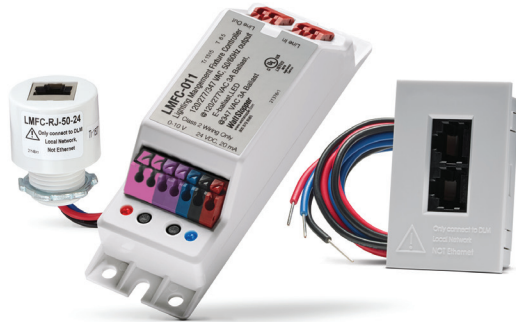

PRODUCT OVERVIEW

The LMFC-011 Fixture Controller mounts in individual lighting fixtures to give them connectivity to a Digital Lighting Management (DLM) system. The controller provides a 0-10 volt signal for control of dimmable loads including compatible LED drivers and electronic

ballasts and connects to the DLM local network via a single- or dual-port RJ45 wiring whip (ordered separately). Each DLM local network can support up to 64 loads. The local network must be powered by a device such as a power booster, zone controller or room controller.

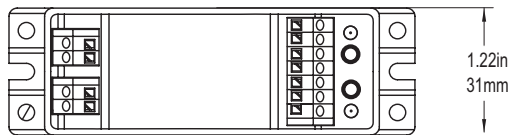

Figure 1. LMFC-011 Dimensions

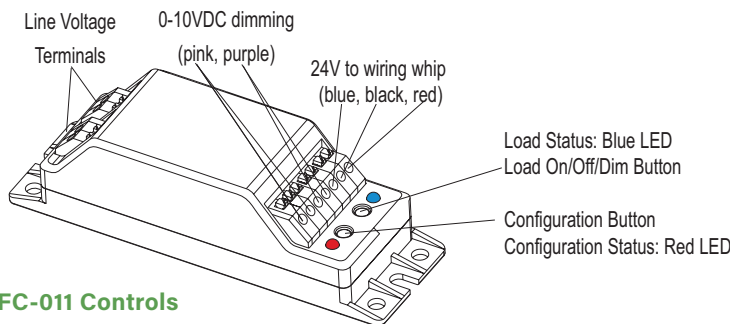
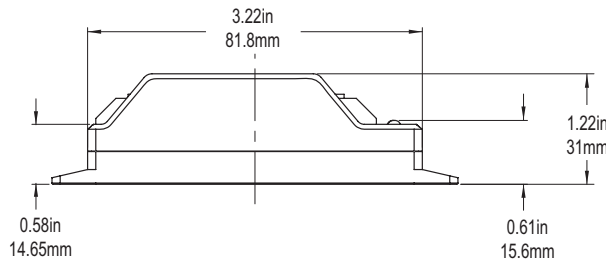

Figure 2. LMFC-011 Controls

MODELS

Fixture Controller:
LMFC-011

Cable Connectors:
LMFC-RJ-50-24 KO mounted
LMFC-2RJ snap-in mounted

Test Kit:
LMKT-OEM1

SPECIFICATIONS & FEATURES

Input voltage: 24VDC

Current consumption: 7mA

Load rating: 120/277/347VAC; 50/60Hz; max load 3A; mechanically latching relay rated for ballast, tungsten, E-ballast, CFL and LED

Class 2 dimming control signal: 0-10VDC, sinks up to 3mA for control of compatible ballasts; IEC 60929

Selectable load parameters: High trim (1-100%); Low trim (0-99%); Scene 1-16 levels (all: 0-100%); Fade time (0 seconds - 18 hours); Preset on level (1-100%); Lamp burn in time (0, 12 or 100 hours)

Local override button for On/Off/Dim; blue LED indicates status of load

Cable connectors allow flexible mounting of controller and wiring port in optimal locations

Weight: LMFC-011 with cable connector 3.7 oz (105 g)

Indoor use only

Operating Temperature: @ 120/277V: 32°F to 158°F (0°C to 70°C), @ 347V: 32°F to 133°F (0°C to 55°C)

Operating Humidity: 5% to 95%, non-condensing

UL and cUL listed (E101196)

FCC part 15 compliant

Five year warranty

MATERIALS

Polycarbonate, flame retardant

Impact resistant

UV grade

Meets materials restrictions of RoH

FACTORY DEFAULTS

High Trim:	85%
Low Trim:	0%
Scene 1-16 Levels:	1=100%; 2=75%; 3=50%; 4=25%; 5-16=100%
Fade Time:	2 seconds
Preset On Level:	60%
Lamp Burn In Time:	0

INSTALLING THE LMFC-011 IN LIGHT FIXTURE

1. Mount the LMFC-011 in the fixture within 24" of the planned location for the cable connector.
2. There are two DLM connector options for mounting to the fixture: The LMFC-RJ-50-24 provides a single RJ-45 port, and the LMFC-2RJ provides two RJ-45 ports (Figure 3).
3. The LMFC-RJ-50-24 requires a hole in the fixture for a standard 1/2" nipple. Mount the LMFC-RJ50-24 to the fixture, securing with the locking nut.
4. For the LMFC-2RJ, see the diagram for the measurements for the hole (Figure 8). The LMFC-2RJ has snap fit tabs to secure it to the fixture.
5. Connect the DLM Local Network adapter wires to the LMFC-011 as shown in the wiring diagram (Figure 5).
6. For dimming ballasts/drivers, connect the 0-10V control wires to the 0-10V terminals on the LMFC-011. Connect the line in to the LMFC-011, and then connect the line out (load) wire from the LMFC-011 to the ballast/driver.

Notes:

- Ballast/driver connections vary. Please reference manufacturer documentation for correct wiring. Multiple 0-10V inputs can be driven by the LMFC-011.
- The OEM may utilize crimp or wire nut connectors to connect to more drivers as needed provided the sourcing does not exceed the LMFC-011 specification of 3mA.
- Installation shall be in accordance with all applicable regulations, local and NEC codes. Fixture assembly, UL Listing compliance, and Class 1 / Class 2 wiring separation best practices are the responsibility of the fixture OEM and/or installing contractor.
- Wire connections shall be rated suitable for the wire size (lead and building wiring) employed.

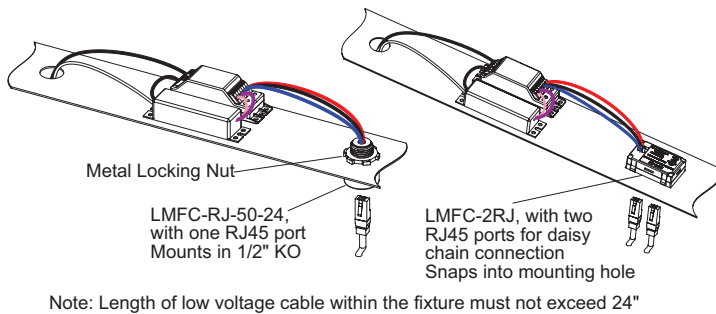
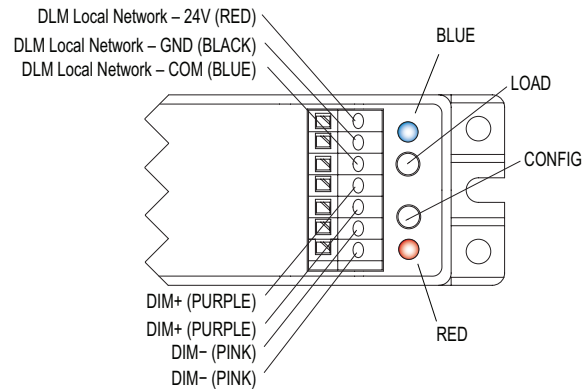
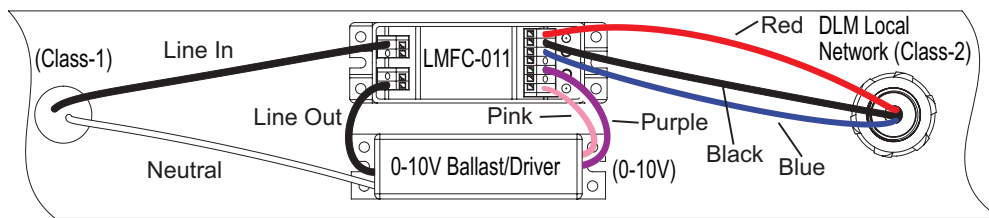
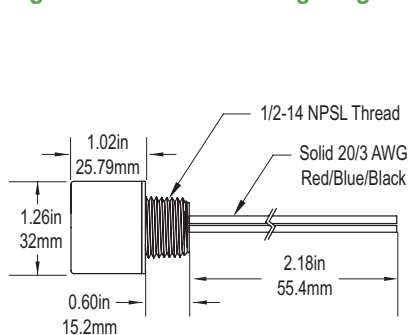
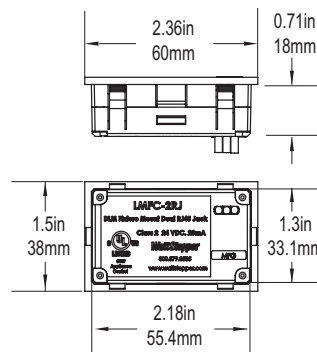
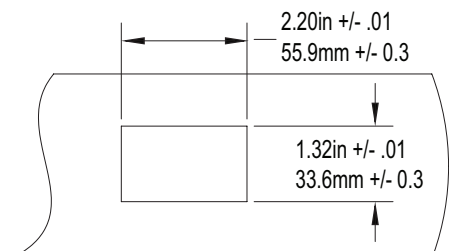
Figure 3. LMFC Cable Connectors mounted to fixture

Figure 4. Detail of LMFC-011 Terminals

Figure 5. LMFC-011 Wiring Diagram

Figure 6. LMFC-RJ-50-24 Dimensions
 LMFC-RJ-50-24 mounts in 1/2" KO

Figure 7. LMFC-2RJ Dimensions

Figure 8. Cutout Dimensions for LMFC-2RJ

TEST PROCEDURE FOR LMFC-011 IN LIGHT FIXTURE

Guideline for QC verification of light fixture controlled by LMFC-011

Required Devices: Wattstopper LMKT-OEM1 Test Kit

Test Fixture Set-up:

1. Connect the LMSW-105 to either RJ45 port on the LMRC-111 using one of the LMRJ cables.
2. Connect the second LMRJ cable to the other port on the LMRC-111 and to the Device-Under-Test (LMFC-011 within the DUT light fixture).
3. Connect 120 or 277 volt power to the LMRC-111 and 120, 277 or 347 power to the DUT via a cable equipped with a toggle switch. If possible, use the same power toggle switch for both devices.

Test Steps:

1. Apply power to the DUT and Test Fixture simultaneously.
2. The Config LED (Red) on the LMFC will turn solid red for a few seconds. [For reference, the Config LED will then blink once every 3 seconds (System 'heartbeat'). Also for reference, the Config LED on the LMRC-111 will function similarly to the Config LED on the LMFC.]

3. Press button 1 on the LMSW-105. The DUT will turn On with dimming level at 100%, and the LMFC Load LED (Blue) will turn on while the load is On. The local network communication to the LMFC is verified.
4. Press LMSW button 2. The DUT will change for dimming level at 75%. The dimming function of LMFC is verified.
5. Press LMSW button 4. The DUT will change for dimming level at 25%.
6. Pressing the bottom of the rocker will turn the load Off and the blue LED Off.
7. Pressing the Load Button on the LMFC will toggle the load On/Off.

Note:

DLM devices can be reset to factory defaults using LMCT-100 (Main Menu - More - Utilities - Force System into PnG).

Figure 9. Connecting LMKT-OEM1 Test Kit devices to Device Under Test (DUT)

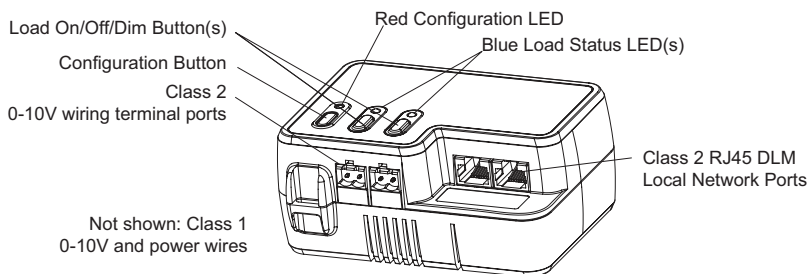
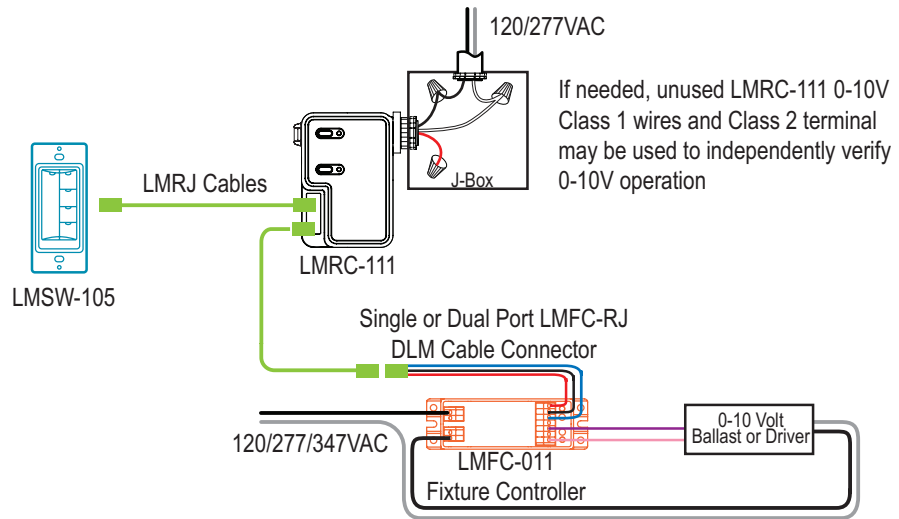

Figure 10. LMRC-112 Detail

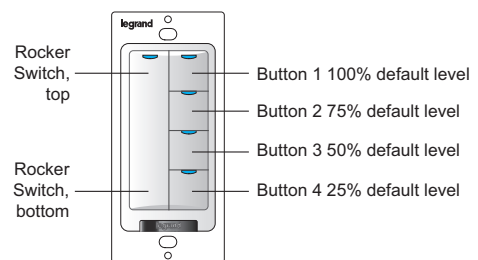
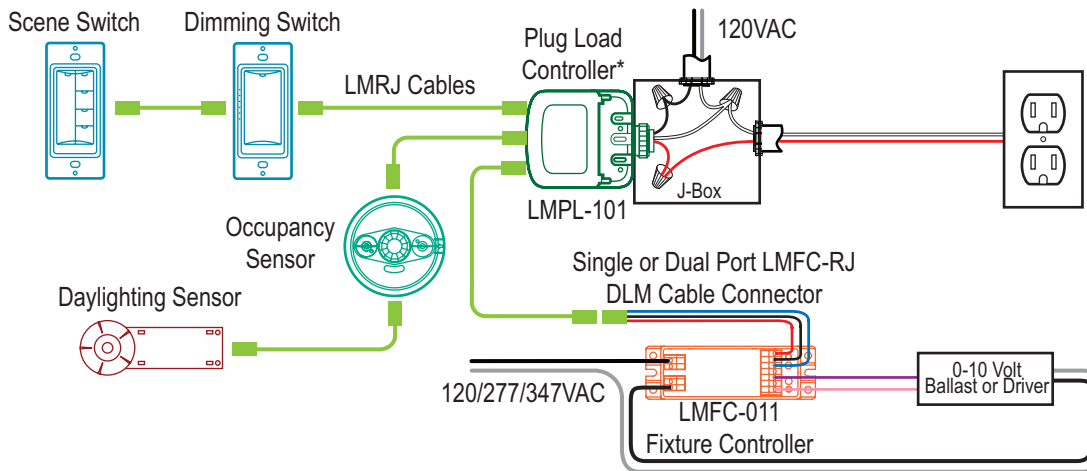

Figure 11. LMSW-105 Detail

SAMPLE DIGITAL LIGHTING MANAGEMENT CONNECT CONNECTION DIAGRAM



* Each DLM local network must include a Zone Controller, Power Booster, Plug Load Controller, Room Controller or Relay Panel to supply low voltage power

SEQUENCE OF OPERATION

The fixture controller operates on 24VDC from the DLM local network, which must be powered by a device such as a zone controller, power booster or room controller. It works with 120/277/347VAC ballasts or drivers. Once powered up, Plug n' Go™ automatically configures DLM system components for the most energy-efficient operation. The fixture controllers then dim or switch lighting loads in response to input from the communicating devices. When a dimming input is received, the relay switches on when the dimmed level rises above zero, and off when it reaches zero, to coordinate control of power and the 0-10 volt signal to the load. Each controller stores up to 16 scene preset levels for each dimmed output.

When fixture controllers are connected only to occupancy sensors, the system defaults to automatic on/off operation. If a wall switch is added to a system with one load, the load defaults to manual-on/automatic-off operation. If there is a wall switch and multiple loads, load one turns on automatically, while additional loads default to manual-on control; all loads turn off automatically. However, if an LMZC zone controller is present, all LMFC fixture controller loads default to automatic-on to 50%.

ORDERING INFORMATION

Catalog #	Master Pack Details				Inner Pack Details					
	Master Pack Quantity	Case dimensions (inches)			Weight (pounds)	Inner Pack Quantity	Case dimensions (inches)			Weight (pounds)
		Length	Width	Height		Length	Width	Height		
LMFC-011	200	21.1	19.72	10.3	29.45	100	20.67	9.45	9.76	13.75
LMFC-RJ-50-24	200	21.1	19.72	10.3	28.65	100	20.67	9.45	9.76	13.45
LMFC-2RJ	200	21.1	19.72	10.3	29.36	100	20.67	9.45	9.76	13.58

Catalog #	Description	Input Voltage	Load Rating
LMFC-011	0-10V dimming fixture controller with relay	24VDC	120/277/347VAC, 3A
LMFC-RJ-50-24	DLM cable connector whip with one RJ45 port and 24" leads; fits 1/2" KO; white		
LMFC-2RJ	DLM cable connector whip with two RJ45 ports and 24" leads; fits rectangular opening; gray		
LMKT-OEM1	Test kit for LMFC-011 fixture controllers (includes LMRC-111, LMSW-105, two LMRJ-10 cables and LMCT-100)	120/277VAC; 50/60Hz	10A

Bulk packaged products are shipped without individual boxes or installation instructions. Information supplied above is subject to change. Harmonization code: 8538908080. Country of origin: China.

31352r1 Rev 05/2021