

LOW VOLTAGE PIR FIXTURE INTEGRATED OCCUPANCY SENSOR

| FS-205 V2



Product Overview

The compact FS-205 form factor makes it ideal for installation in task lights and other small fixtures.

FS-205 occupancy sensors turn lighting on and off based on occupancy and ambient light levels. The sensors use passive infrared (PIR) occupancy sensing technology that reacts to changes in infrared energy (moving body heat) within the coverage area. Once the space is vacant and the time delay elapses, lights will turn off. Sensors must directly “see” motion to detect occupant, so careful consideration must be given to sensor placement. Avoid placing the sensor where shelving or other obstructions may block the sensor’s line of sight.

The light level capability prevent lights from turning on if ambient light levels are sufficient.

Operating at 24VDC, the FS-205 is designed for installation in a light fixture within 6’ of an associated power supply (an FS-PP power pack also mounted inside the fixture). Each power pack can supply power for up to seven FS-205 sensors.

Sensors are equipped with a 6’ long cable fitted with a male RJ45 plug that connects to the corresponding female RJ45 receptacle on the FS-PP. This cable carries power to the sensor and the 24VDC maintained output to the power pack to signal that lights should be on.

Models
FS-205 v2
Specifications and Features
Operating voltage: 24 VDC
Power consumption: 6.5 mA @ 24VDC
Dimensions:
Throat: 0.75" (19mm) diameter
Lens collar: 1.12" (28.5mm) diameter
Lens pipe: 0.38" (9.7mm)
Sensor body: 1.12" L x 1.38" D x 0.5" W (28.5mm x 35mm x 12.7mm)
Weight: 1.6 oz (45.4 g)
Requires FS-PP Power Pack for operation
Adjustable time delay (30 seconds to 30 minutes)
Integrated photosensor for Hold-off daylighting control
LED indicator of occupancy detection
Low-voltage 6-ft. whip with RJ45 connector
Compact design ideal for low profile fixtures
UL and cUL listed
Indoor use only
Operating conditions: 32°F to 131°F (0°C to 55°C); 5% to 95% RH, non condensing
Five year warranty
Materials
ABS, Flame retardant
Factory Defaults
Time Delay: 30 seconds
Light Level: 120 footcandles

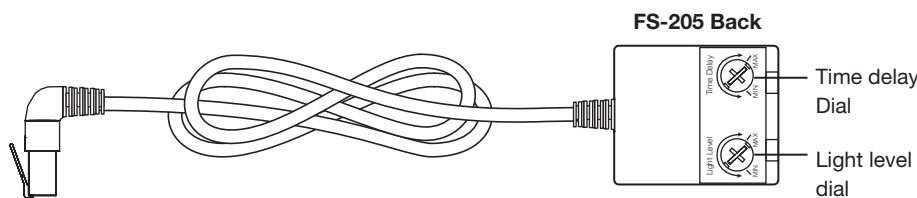
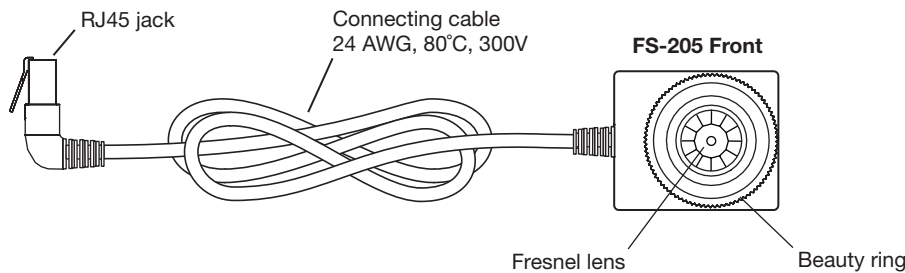

Coverage and Detection Features

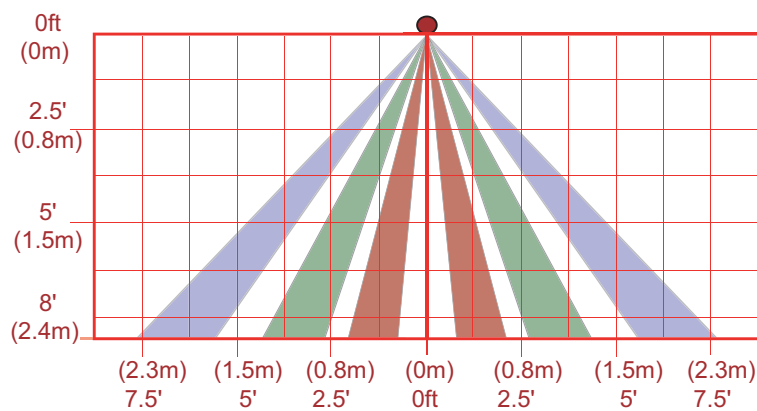
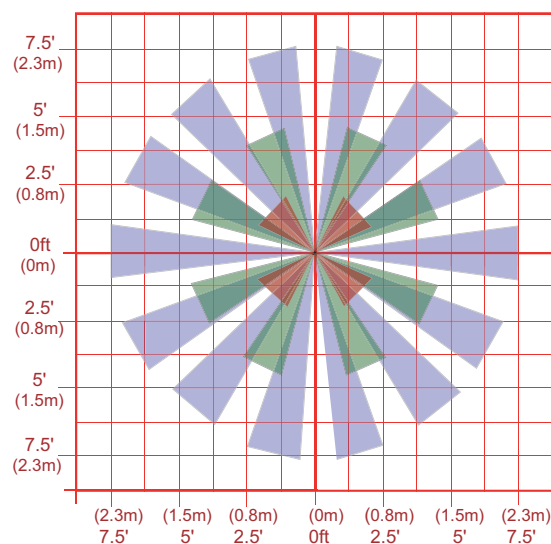

Density and range of the coverage pattern is determined by mounting height. The FS-205 has a multi-cell, multi-tier Fresnel lens with a 360° view. This lens is designed to detect small motion when mounted within 6' of occupants. Coverages shown represent full step walking motion, with no barriers or obstacles. When mounted at a height of 10', the coverage area is approximately 15' diameter.

The light level feature holds lights off upon initial occupancy if adequate ambient light exists. It will not turn the lights off if they are on. The default setting is for maximum, so that the sensor will turn lighting on whenever it detects motion, even when ambient light is brightest.

Dimensions

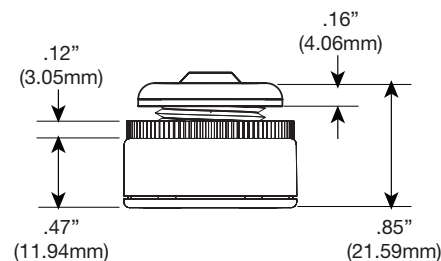
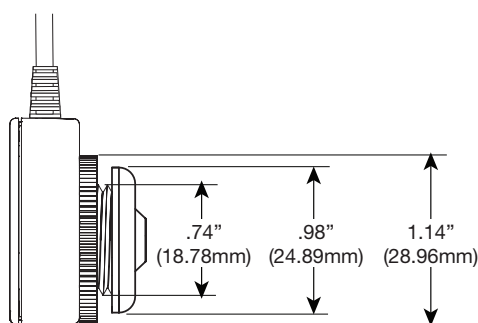
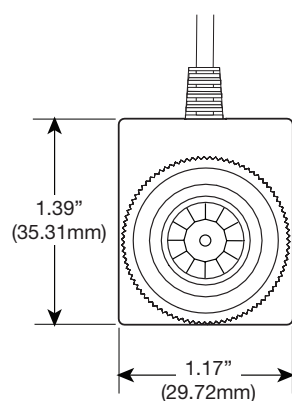

Installing the FS-205 Sensor and FS-PP Power Pack in Light Fixture

1. Install the FS-PP as directed in the installation instructions provided with the power pack.
2. Determine an appropriate mounting location for the FS-205 inside the light fixture. Cut a 3/4" diameter hole through the sheet metal in the bottom of the fixture.
3. A beauty ring and thumbscrew collar are supplied to secure the FS-205 lens through the fixture wall. Depending on the wall thickness and curvature, the installer may need to use the thumbscrew collar on the inside or outside of the fixture, or not at all. Remove the beauty ring and thumbscrew collar from the FS-205 lens pipe.
4. Insert the lens from the inside of the fixture, through the hole in the bottom of the fixture. If the lens extends too far outside the fixture, use the thumbscrew collar to adjust the depth. Tighten it to the outside of the fixture or tighten it against the sensor body before inserting the lens through the fixture wall. Then, put the beauty ring onto the lens pipe and tighten it securely.

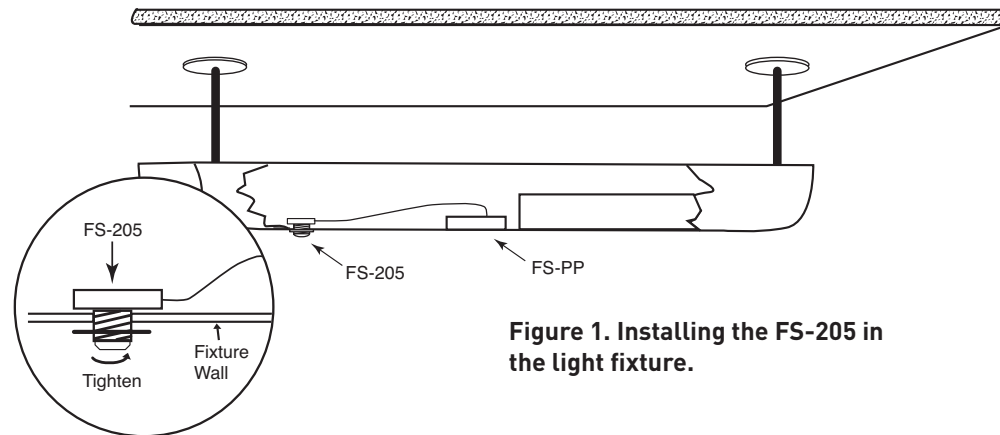

Figure 1. Installing the FS-205 in the light fixture.

Wiring Diagrams

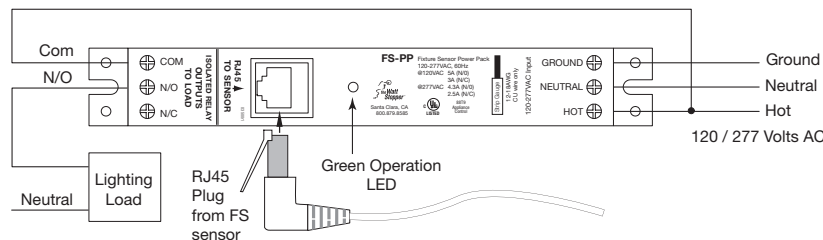

Figure 2. FS-PP wiring for On/Off control.

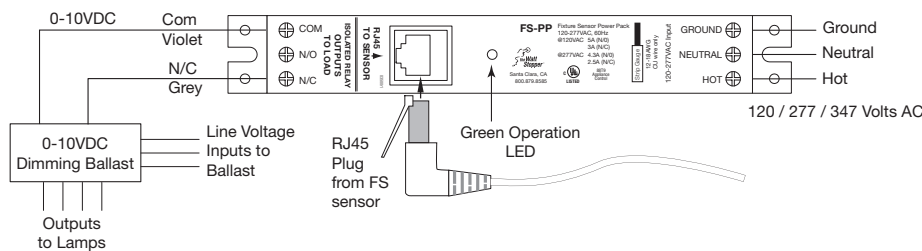

Figure 3. FS-PP wiring for High/Low control.



Figure 4. Standard connection between FS sensor and FS-PP power pack

Wiring Diagrams

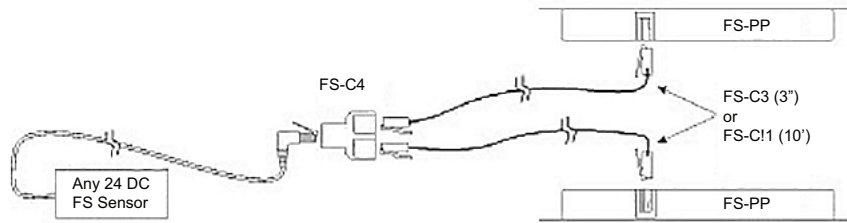

Figure 7. One FS sensor connected to two FS-PP power packs

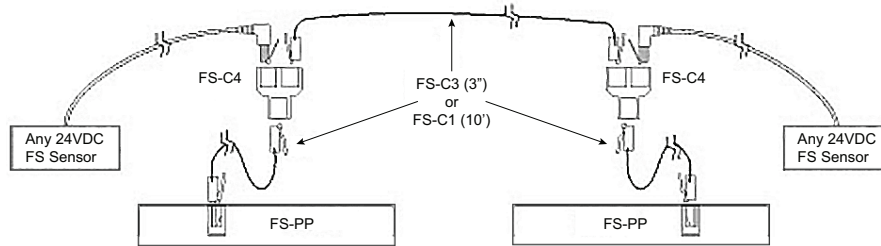

Figure 8. Two FS sensors connected to two FS-PP power packs

Sequence of Operation

It may take up to a minute for the sensor to warm up during the initial power-up. The sensor has an “instant on” feature. This occurs during installation or after a lengthy power failure only. As soon as power is supplied to the FS-PP, the lights will come on and stay on for approximately 1 minute. If no movement is detected within that time the lights will turn off until detection occurs. If movement is detected during the initial 1 minute then the lights will stay on for whatever time has been set on the time delay.

Ordering Information

Catalog #	Master Pack Details					Inner Pack Details				
	Master Pack Quantity	Case dimensions (inches)			Weight (pounds)	Inner Pack Quantity	Case dimensions (inches)			Weight (pounds)
		Length	Width	Height			Length	Width	Height	
FS-205 v2	144	16.34	12.76	20.28	29.36	36	19.68	7.76	5.98	6.8
FS-PPv2	100	21.14	19.72	10.31	21.8	N/A	N/A	N/A	N/A	N/A
FS-C1	160	14.17	14.17	11.02	31.62	10	13.78	9.06	2.0	1.9
FS-C3	350	13.98	13.39	18.5	28.08	10	13.78	9.06	2.0	0.76
FS-C4	750	16.34	12.76	20.28	40.0	15	9.0	7.0	1.0	0.76
FS-C5	600	14.17	14.17	11.02	22.34	30	12.0	6.0	1.0	1.04

Catalog #	Color	Description	Input Voltage
<input type="checkbox"/> FS-205 v2	White	Fixture mount, low voltage PIR occupancy sensor with adjustable time delay and light level	24 VDC
<input type="checkbox"/> FS-PP v2	White	Fixture Sensor Power Pack	120/277/347 VAC; 60Hz
<input type="checkbox"/> FS-C1		10' cable with shielded RJ45 male connectors at each end	
<input type="checkbox"/> FS-C3		3' cable with shielded 90° male RJ45 on one end and shielded straight male RJ45 on other end	
<input type="checkbox"/> FS-C4		Shielded RJ45 splitter with female to dual female receptacles	
<input type="checkbox"/> FS-C5		Shielded RJ45 male to male coupler	

Information supplied above is subject to change.
 Harmonization code: 8538908080. Country of origin: China.