



FEATURES

The LB-2108FB-4CH is an industrial level DMX512 & RDM LED controller with 4-channel constant voltage that supports real 16-bit PWM resolution. Designed with easily interchangeable master and slave mode, and features full support for the latest DMX512, DMX512(1990), DMX512-A, and RDM V1.0 (E1.20 - 2006 ESTA standard) protocols. Includes 4 channels to provide 5A per channel constant voltage output, and is available in 12VDC, 24VDC, and 36VDC variants. Additionally, this DMX controller is equipped with easy wiring terminals that do not require screws.

- RDM bi-directional communication function enables the DMX512 master console to detect and display decoder information and set DMX addresses while in decoder mode.
- Visible numeric digital display and buttons allow configuration of DMX address, output channel quantity, PWM output resolution (8-bit or 16-bit), PWM output frequency, GAMMA ray dimming curve value, and DMX decoding mode.
- Metal outer shell, IP20 rating (dust proof, dry environments only).

Under Master Mode

- 32 built-in programs for RGB static colors or color-changing patterns
- Capable of controlling and adjusting the color temperature of CW and WW dual-color LEDs
- 8 levels of RGB brightness adjustment
- 16 levels of pattern changing speed adjustment

Under Slave Mode

- Total 4 PWM output channels, common anode.
- DMX channel quantity from 1CH to 4 CH settable.
- Enable DMX512 master console to detect decoder, display decoder information and set DMX address.
- PWM output high frequency 16bit and low frequency 8bit switchable, default setting is 16bit
- 10 levels of PWM output frequency optional from 500Hz-30kHz, default setting is 1kHz.
- Optional decoding modes allow for adjusting the brightness of each channel, master brightness of all channels, and strobe. The default mode is dp1.1.
- The gamma ray curve value is adjustable from 0.1 to 9.9, with optional logarithmic and linear dimming.

COMPATIBILITY

Compatible with all following controllers:

- LB-2812WI RGBW DMX512+WiFi Controller/3 Zones.
- LB-2830BDMX Dual Color DMX512 Controller/4 Zones.
- LB-2834-5C-DMX RGB+Dual Color DMX512 Wall Panel Controller.

Once paired with a controller, decoder can be used with any Lumi-PRO Elite tape light.

DIMENSIONS

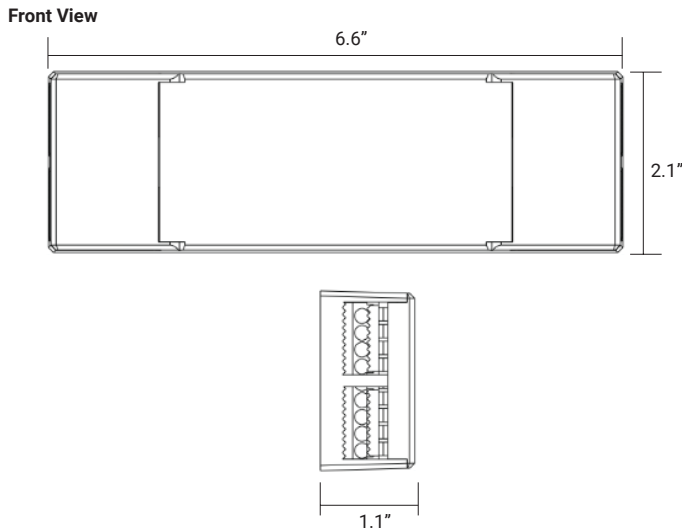

TECHNICAL DETAILS

Input Voltage	12-36VDC
Output Current	4x5A
Output Power	4x(60-180)W
Dimensions	6.6"X2.1"X1.1"
Operating Temperature	-20°C to 50°C / -4°F to 122°F

Output PWM Frequency	500HZ - 35K HZ settable
Certifications	FCC / RoHS
Color	White
IP Rating	IP 20 / Ingress protection, Keep Dry
Warranty	5-year warranty for parts and components (labor not included)

WIRING DIAGRAM

SAFETY

DO NOT install with power applied to device.

DO NOT expose the device to moisture.

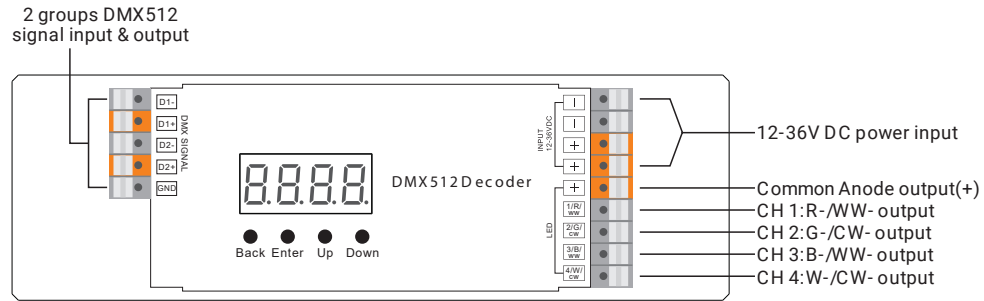

1. Master mode

When total load of each receiver is not over 10A

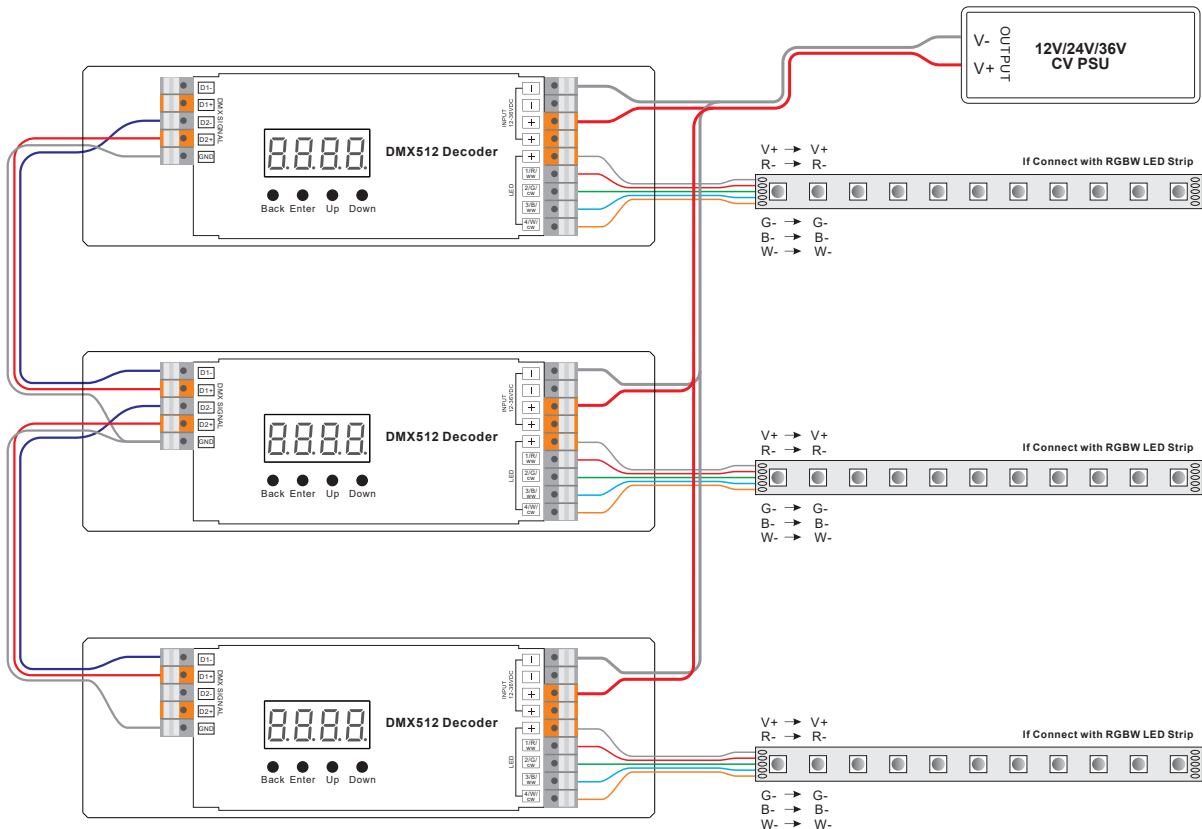

Master mode

When total load of each receiver is over 10A

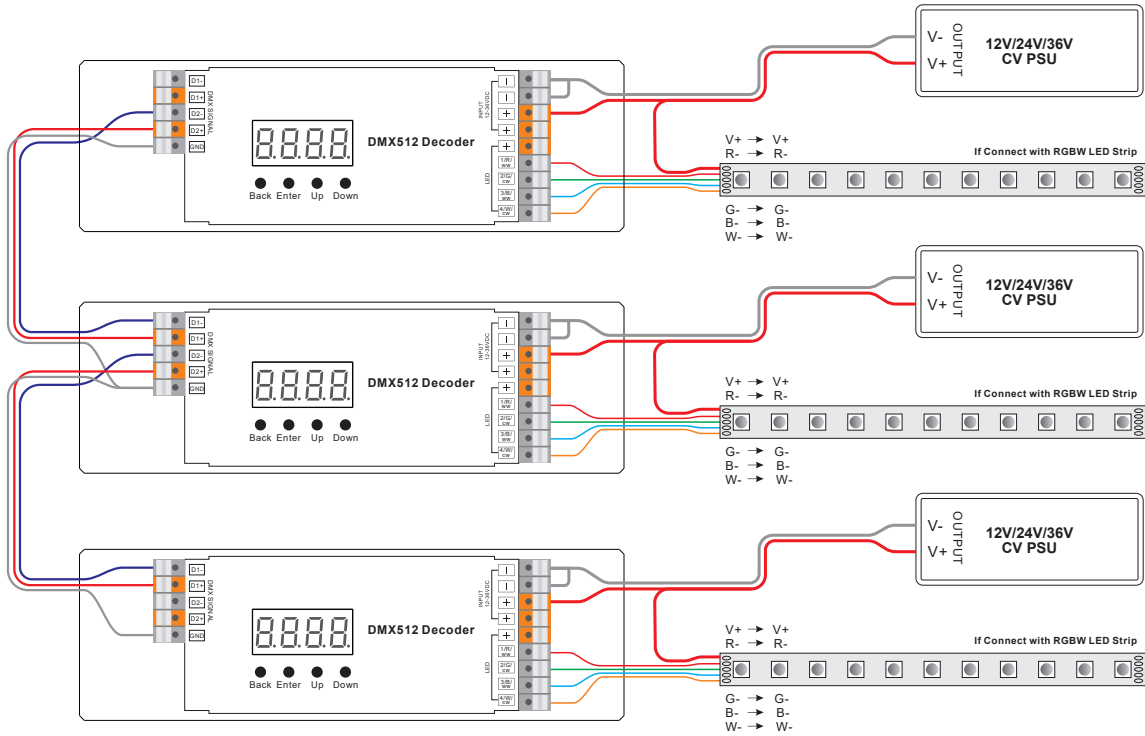

2. Decoder mode

When total load of each receiver is not over 10A

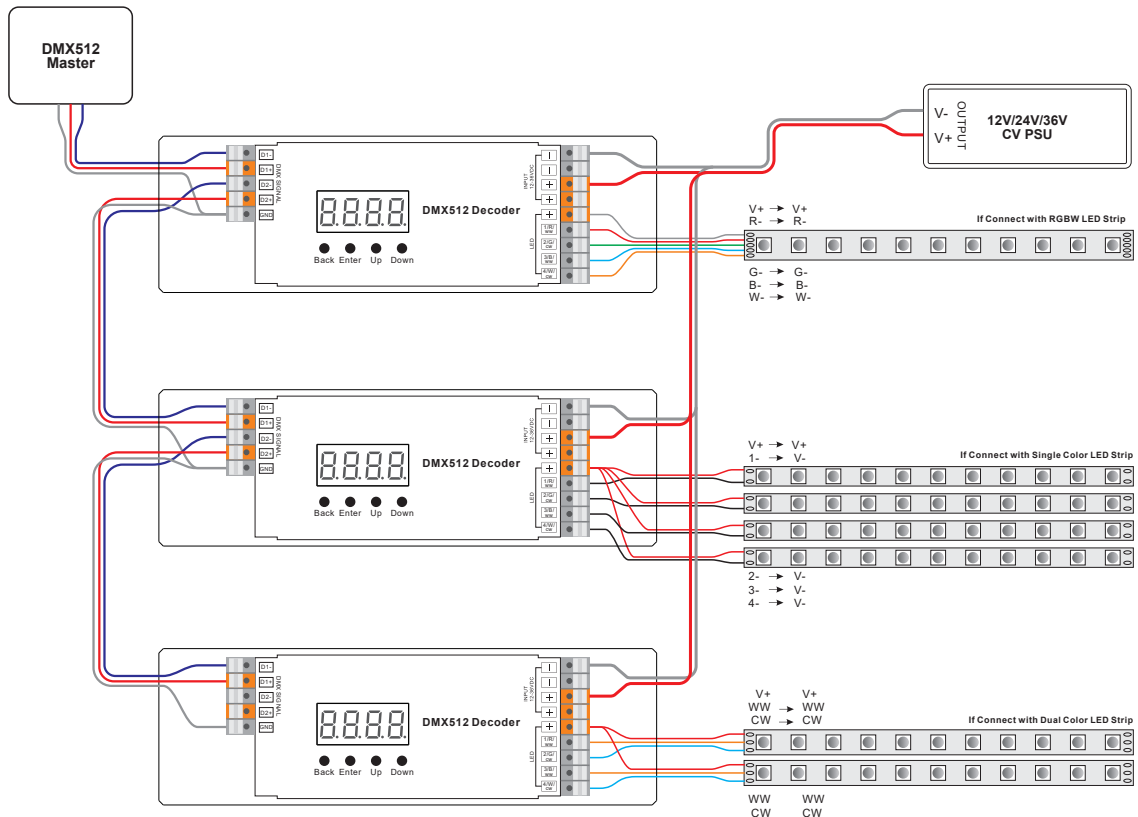

Decoder mode

When total load of each receiver is over 10A

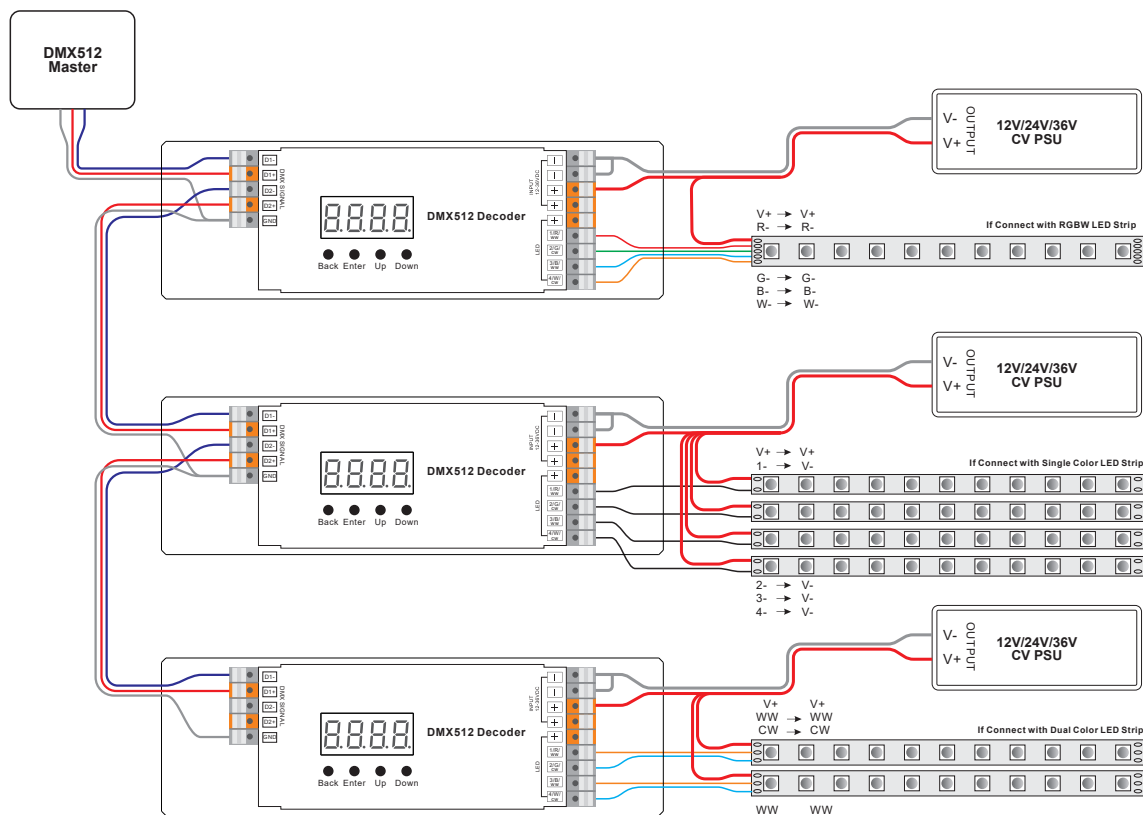

OPERATION

Before proceeding with other settings, please ensure that the device is set to either Master or Decoder mode.

run1 = DMX Decoder mode, **run2** = DMX Master mode(stand alone).

Continuously press the Down button to cycle through options until 'run1' or 'run2' is displayed. Press Enter to confirm your selection, and then use the Down button again to choose either 1 or 2. After making your selection, press the Back button.

Once you have chosen either 'run1' or 'run2', please power off the device and then power it on again

1. In run2 DMX Master mode: After powering on the device, continue pressing the Up button. This will display the below menu options on the screen.

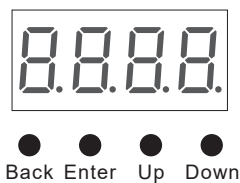

0.0.0.0 This section refers to the brightness settings for each output PWM channel. The first digit '1' corresponds to PWM output channel 1, which can be selected from channels 1 to 4 by using the 'UP' or 'Down' buttons.

The second part, '01', indicates the brightness level. After selecting the desired channel, press the 'Enter' button. The display will flash, indicating readiness for adjustment. Use the 'UP' or 'Down' buttons to select a brightness level ranging from 00 to 99, or 'FL' for full brightness (100%). Confirm your selection by pressing the 'Back' button."

P.XXX Refers to programs, with a total of 1 to 31 programs available.

B-.XX Refers to the brightness level of the RGB running effect, with a total of 1 to 8 levels available.

SP.-X Indicates the play speed of the effect, with a total of 1 to 9 speed levels.

P-XX means RGB color changing modes, with a total of 31 programs:

- 00- RGB off
- 01- Static red
- 02- Static green
- 03- Static blue

04- Static yellow (50% red+50% green)

05- Static orange (75% red+25% green)

06- Static cyan (50% green+50% blue)

07- Static purple (50% blue+50% red)

08- Static white (100% red+100% green+100% blue)

09- Any two colors of RGB mix fade, changing diagram as follows:

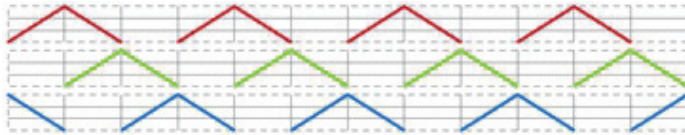

10- RGB colors mix fade, changing diagram as follow:

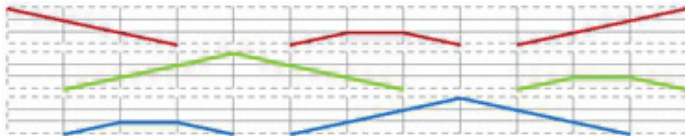

11- RGB FADE OUT & FADE IN, changing diagram as follow:

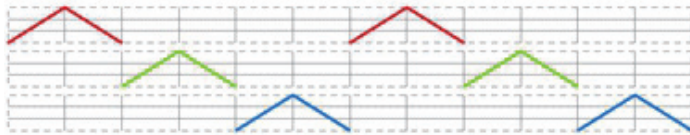

12- RGB jump changing, changing diagram as follow:

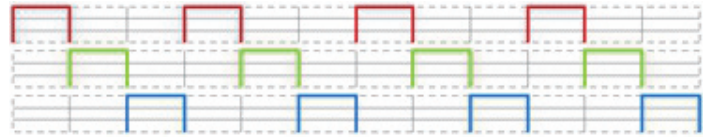

13- RGB FADE IN, changing diagram as follow:



14- RGB FADE OUT, changing diagram as follow:

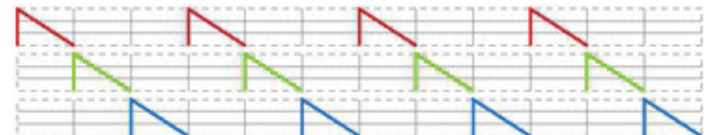

15- RGB 3 colors strobe

16- White color strobe (100% red+100% green+100% blue)

17- 7 colors FADE OUT & FADE IN (red, orange, yellow, green, cyan, blue, purple FADE OUT & FADE IN)

18- 7 colors jump changing (red, orange, yellow, green, cyan, blue, purple jump changing)

19- 7 colors strobe (red, orange, yellow, green, cyan, blue, purple strobe)

20- Red-white (100% red+100% green+100% blue) circle gradual changing

21- Green-white (100% red+100% green+100% blue) circle gradual changing

22- Blue-white (100% red+100% green+100% blue) circle gradual changing

23- Red-orange circle gradual changing

24- Red-purple circle gradual changing

25- Green-yellow circle gradual changing

26- Green-cyan circle gradual changing

27- Blue-purple circle gradual changing

28- Blue-cyan circle gradual changing

29- Red-yellow-green circle gradual changing

30- Red-purple-blue circle gradual changing

31- Green-cyan-blue circle gradual changing

run2 Means the device at run2 mode (DMX master, standalone).

To make a setting is like this: Up/Down--- Enter--- Up/Down---Back

II. For run1 DMX decoder mode: After powering on the decoder, if you continue to press the up button, you will find the following menu displayed.

DMX signal indicator ● :: When DMX signal input is detected, the indicator on the display following after **8** turns on red **8.XXX** .

8888 you will get this after power on the decoder, it means this decoder supports firmware OTA update function.

8.XXX Means the DMX address default setting is 001.

88XX Refers to the quantity of DMX channels.

8EXX Means Bit (8bit or 16bit). factory defaults setting is 16bit

8FXX Refers to the output PWM frequency, with the factory default setting being 1 kHz.

8GXX Refers to the output dimming curve gamma value, with the factory default setting being gamma 1.5

8PXX Refers to the decoding mode, with the factory default setting being dp 1.1.

run1 Refers to the device operating in run 1 mode (DMX decoder).

By holding down the back and enter buttons together for over 5 seconds until the display goes off, it will restore default settings.

1.DMX Address settings:

select menu **8.XXX** click button "Enter", display flashes, then click or hold button "Up" / "Down" to set DMX address (click is slow, hold is fast.), then click button "Back" to confirm.

2.DMX Channel Quantity Settings:

Select menu **88XX** click button "Enter", display flashes, then click button "Up" / "Down" to set DMX channel quantity, then click button "Back" to confirm.

For example the DMX address is already set 001.

CH01=1 DMX address for all the output channels, which are all address 001.

CH02=2 DMX addresses, output 1&3 is address 001, output 2, & 4 is address 002.

CH03=3 DMX addresses, output 1, 2 is address 001,002, output 3,4 is address 003.

CH04=4 DMX addresses, output 1,2,3, 4 is address 001,002,003,004.

3.PWM Output Resolution Bit Settings

select menu **8EXX** click button "Enter", display flashes then click button "Up" / "Down" to choose 08 or 16 bit, then click button "Back" to confirm.

4.Output PWM frequency Settings:

select menu **8FXX** click button "Enter", display flashes, then click button "Up" / "Down" to choose 00~35, then click button "Back" to confirm. 00=500HZ, 01=1kHz, 02=2kHz.....30=30kHz.

5.Output Dimming Curve Gamma Values Settings:

select menu **8GXX**, click button "Enter", display flashes, then click or hold button "Up" / "Down" to choose 0.1~9.9, then click button "Back" to confirm.

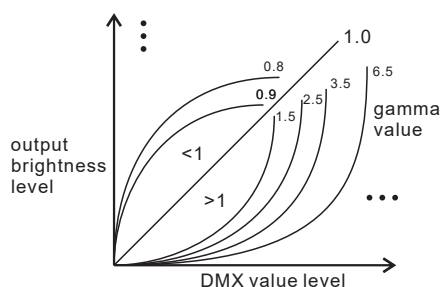

6.DMX Decoding Mode Settings:

Select menu **8PXX** click button "Enter", display flashes, then click or hold button "Up" / "Down" to choose the decoding mode, then click button "Back" to confirm. " dPxx" means the DMX address quantity used for control of corresponding PWM output channel quantity. 1st "x" is DMX address quantity, 2nd "x" is PWM channel quantity.

The fine dimming effect, characterized by micro dimming, becomes noticeable only when the dimming curve gamma value is set lower than 1.4. The lower the value, the more pronounced the fine dimming effect becomes.

Firmware OTA Update:

This function facilitates firmware updates provided by the manufacturer. The update process requires a Windows computer and a USB to serial port converter. The converter establishes a connection between the computer and the decoder's hard-wired DMX port. A software RS485-OTW on the computer is utilized to initiate the firmware transfer to the decoder.

To execute the update:

Connect the computer and the decoder via the USB to serial port converter.
 If updating multiple decoders, connect the converter to the first decoder's DMX port.
 Subsequently, connect the other decoders to the first decoder in a daisy chain configuration through the DMX port.
 Note: It is essential not to power on the decoders during the update process.

To execute the firmware update process, run the OTA tool RS485-OTW on the computer. Select the correct communication port "USB-SERIAL", set the baud rate to "250000", and the data bit to "9", while maintaining default settings for other configurations. Click the "File" button to select the new firmware from the computer, then click "Open Port" to establish the connection. Once connected, click "Download Firmware" to initiate the transfer. The right-side state column will indicate "send link". Power on the decoders before "wait erase" displays on the state column; the digital display will show **ERRR**. Upon "wait erase" appearing, indicating the start of the update, the OTA tool will write data to the decoders. The state column will show the progress, and upon completion, the digital display will flash **ERRR** confirming a successful firmware update.

The data definitions for strobe channel are as follows:

```
{0, 7},//undefined
{8, 65},//slow strobe-->fast strobe
{66, 71},//undefined
{72, 127},//slow push fast close
{128, 133},//undefined
{134, 189},//slow close fast push
{190, 195},//undefined
{196, 250},//random strobe
{251, 255},//undefined
```

The supported RDM PIDs are as follows:

```
DISC_UNIQUE_BRANCH
DISC_MUTE
DISC_UN_MUTE
DEVICE_INFO
DMX_START_ADDRESS
IDENTIFY_DEVICE
SOFTWARE_VERSION_LABEL
DMX_PERSONALITY
DMX_PERSONALITY_DESCRIPTION
SLOT_INFO
SLOT_DESCRIPTION
MANUFACTURER_LABEL
SUPPORTED_PARAMETERS
MODULATION_FREQUENCY
MODULATION_FREQUENCY_DESCRIPTION
CURVE
CURVE_DESCRIPTION
```

Restore to Factory Default Setting

Press and hold down both "Back" and "Enter" keys until the digital display turns off, then release the keys, system will reset and the digital display will turn on again, all settings will be restored to factory default.

Default settings are as follows:

```
DMX Address Code: a001
DMX Address Quantity: SW1=0: ch04, SW1=1: ch03
PWM Resolution Mode: bt16
PWM Frequency: pf01
Gamma: ga1.5
Decoding Mode: dp1.1
```