

The Tension track is available to install with a maximum 45° in any direction between walls.

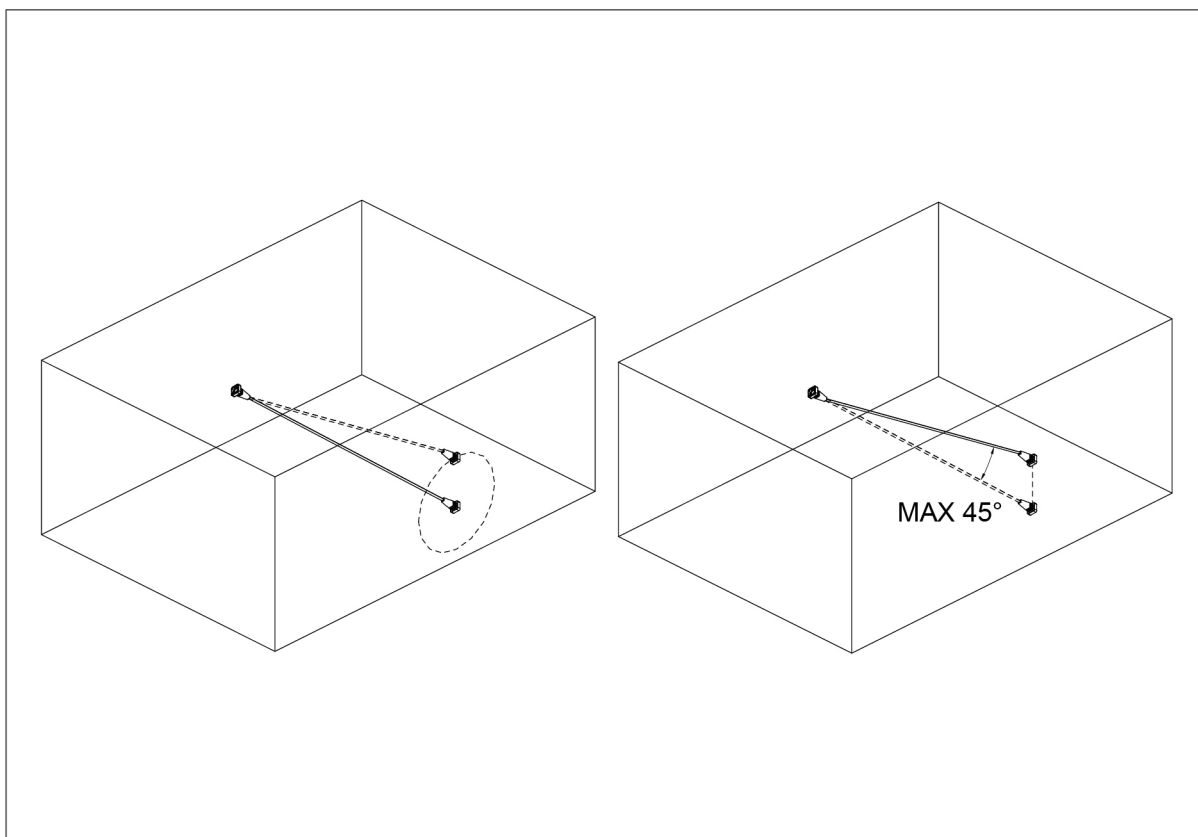

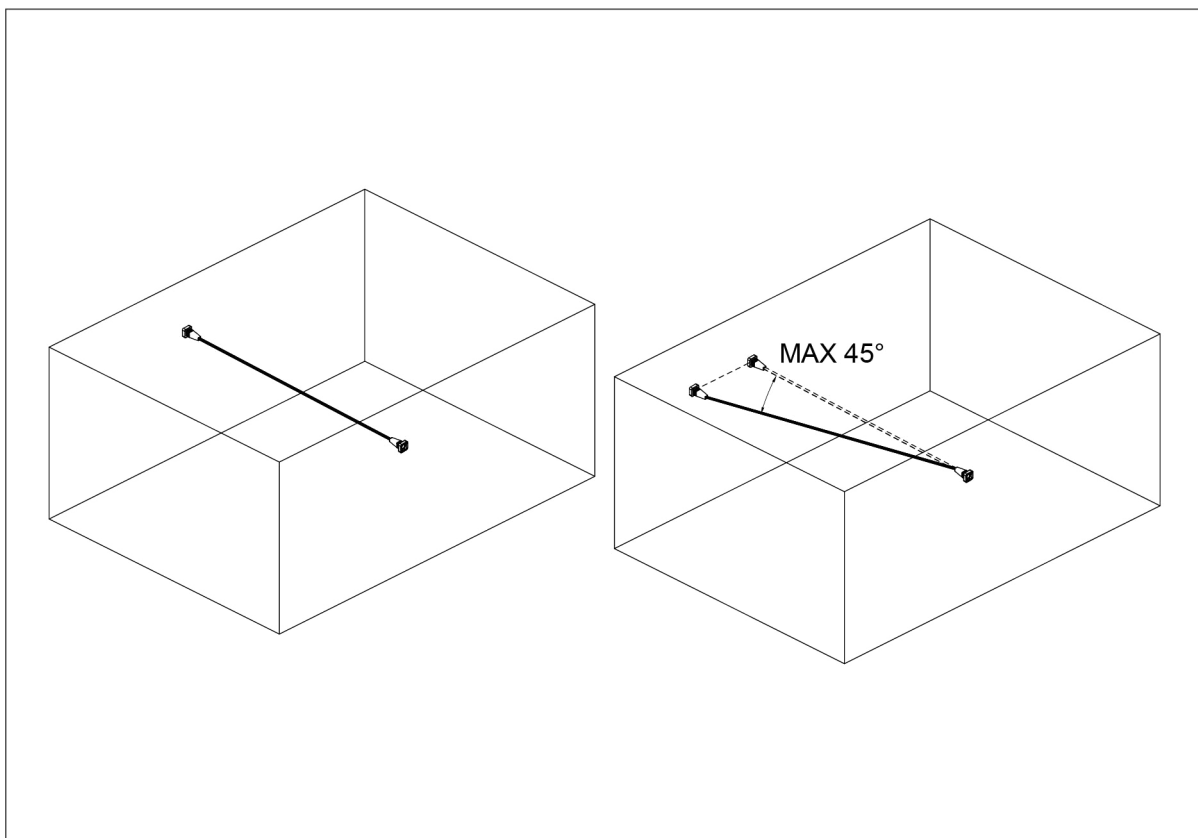
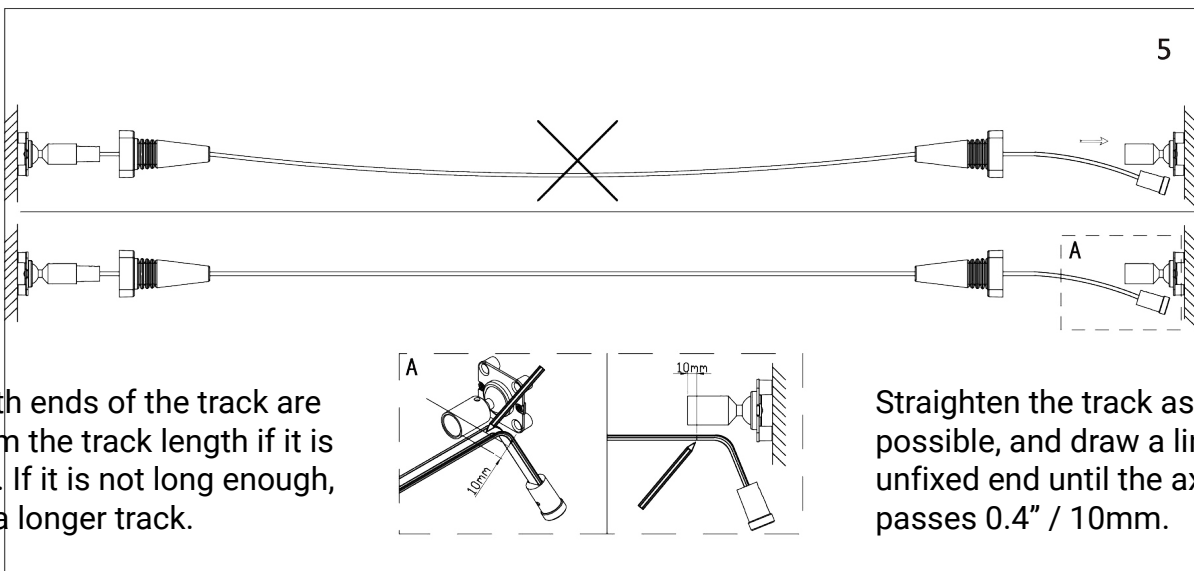
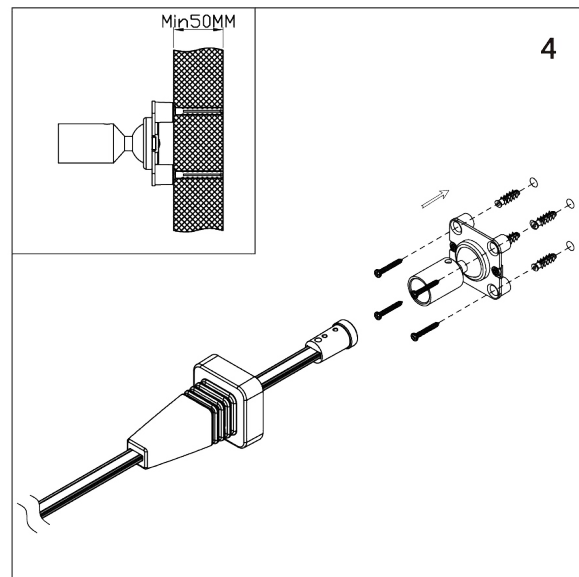
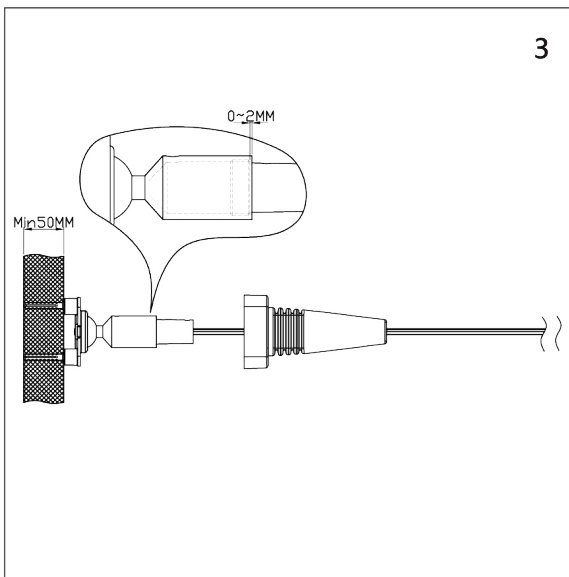
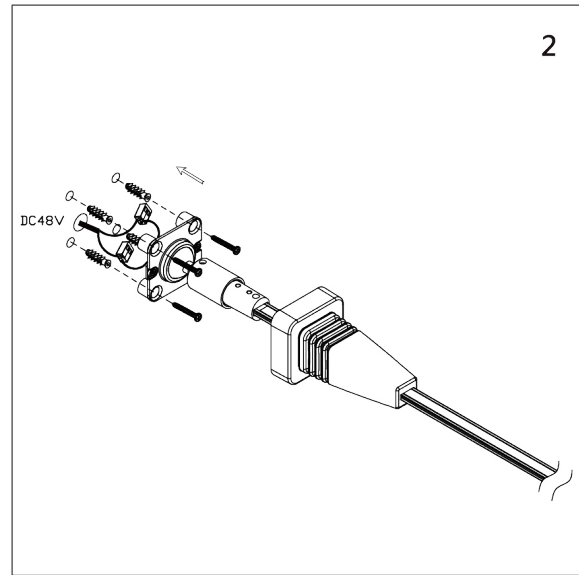
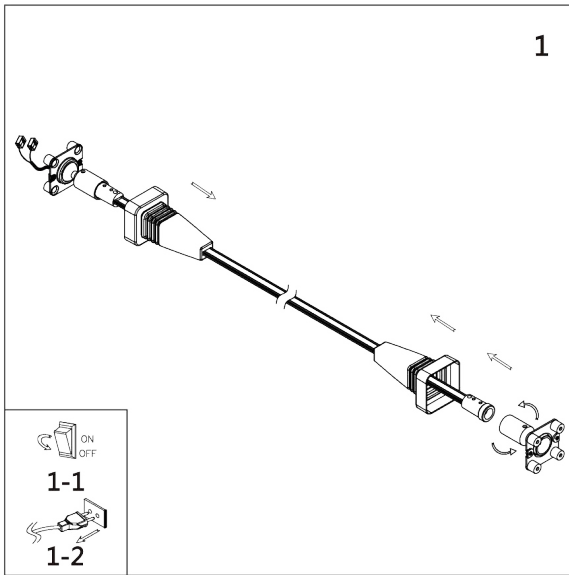

After both ends of the track are fixed, trim the track length if it is too long. If it is not long enough, choose a longer track.

Straighten the track as much as possible, and draw a line on the unfixed end until the axis passes 0.4" / 10mm.

